

Service  
Service  
**Service**CL 36532024\_000.eps  
210303

# Service Manual

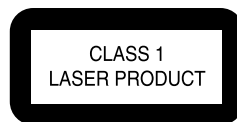

<b>Contents</b>		<b>Page</b>
1	Technical Specs and Connection Facilities	2
2	Safety Instructions, Warnings, Notes,	3
3	Directions for Use	4
4	Mechanical- and Dismantling Instructions	17
5	Service Hints, Trouble Shooting, and Fault Finding	20
6	<i>Wiring-, Block Diagrams</i>	
	Block Diagram	27
	Wiring Diagram	28
	Testpoint Overview MPEG Board	29
7	<i>Electrical Diagrams and Print-Layouts</i>	<i>Diagram PWB</i>
	Power Supply Unit	30 NA
	Display Board	31 32
	AV Board	33 33
	SD5.4 MPEG Board: Index (Diagram M1)	34 39
	SD5.4 MPEG Board: RF Part (Diagram M2)	35 39
	SD5.4 MPEG Board: Servo Part (Diagram M3)	36 39
	SD5.4 MPEG Board: Memory & Audio Parts (Diagram M4)	37 39
	SD5.4 MPEG Board: Video Part (Diagram M5)	38 39
8	Alignments (Not Applicable)	41
9	Circuit Descriptions (Not Applicable)	41
	List of Abbreviations (Not Applicable)	41
	IC Data	42
10	Spare Parts List	43
10	Revision List	46

©Copyright 2003 Philips Consumer Electronics B.V. Eindhoven, The Netherlands.  
All rights reserved. No part of this publication may be reproduced, stored in a  
retrieval system or transmitted, in any form or by any means, electronic,  
mechanical, photocopying, or otherwise without the prior permission of Philips.



# 1. Technical Specifications

## **PLAYBACK SYSTEM**

DVD Video  
 Video CD & SVCD  
 CD  
 PICTURE CD  
 MP3-CD  
 CD-R, CD-RW  
 DVD+R, DVD+RW

## **TV STANDARD (PAL/50Hz) (NTSC/60Hz)**

Number of lines	625	525
Playback	Multistandard	(PAL/NTSC)

## **VIDEO PERFORMANCE**

CVBS	1Vpp — 75
RGB (SCART)	0.7Vpp into 75 ohm

## **AUDIO FORMAT**

Digital	Mpeg/ AC-3/ DTS	compressed Digital
	PCM	16, 20, 24 bits fs, 44.1, 48, 96 kHz
	MP3(ISO 9660)	96, 112, 128, 256 kbps & variable bit rate fs, 32, 44.1, 48 kHz

Analog Sound Stereo  
 Dolby Surround compatible downmix from Dolby Digital  
 multi-channel sound  
 3D Sound for virtual 5.1 channel sound on 2 speakers

**Specifications subject to change without prior notice**

## **AUDIO PERFORMANCE**

DA Converter	24bit	
DVD	fs 96 kHz	4Hz- 44kHz
	fs 48 kHz	4Hz- 22kHz
SVCD	fs 48 kHz	4Hz- 22kHz
	fs 44.1kHz	4Hz- 20kHz
CD/VCD	fs 44.1kHz	4Hz- 20kHz
Signal-Noise (1KHz)		105 dB
Dynamic range(1KHz)		100 dB
Crosstalk (1KHz)		105 dB
Distortion/noise (1KHz)		90 dB
MPEG MP3	MPEG Audio L3	

## **CONNECTIONS**

Scart Output	Euroconnector
Video Output	Cinch (yellow)
Audio Output(L+R)	Cinch (black/white)
Digital Output	1 coaxial, 1 optical
	IEC958 for CDDA / LPCM
	IEC1937 for MPEG 1/2, Dolby
	Digital and DTS

## **CABINET**

Dimensions (w x d x h)	435 x 43 x 300 mm
Weight	Approximately 2.8 Kg

## **POWER CONSUMPTION**

Power consumption in Standby mode	<1W
-----------------------------------	-----

## 2. Safety Instructions, Warnings, Notes, and Service Hints

### 2.1 Safety Instructions

#### 2.1.1 General Safety

Safety regulations require that during a repair:

- Connect the unit to the mains via an isolation transformer.
- Replace safety components, indicated by the symbol , only by components identical to the original ones. Any other component substitution (other than original type) may increase risk of fire or electrical shock hazard.

Safety regulations require that after a repair, you must return the unit in its original condition. Pay, in particular, attention to the following points:

- Route the wires/cables correctly, and fix them with the mounted cable clamps.
- Check the insulation of the mains lead for external damage.
- Check the electrical DC resistance between the mains plug and the secondary side:
  1. Unplug the mains cord, and connect a wire between the two pins of the mains plug.
  2. Set the mains switch to the 'on' position (keep the mains cord unplugged!).
  3. Measure the resistance value between the mains plug and the front panel, controls, and chassis bottom.
  4. Repair or correct unit when the resistance measurement is less than 1 MΩ.
  5. Verify this, before you return the unit to the customer/user (ref. UL-standard no. 1492).
  6. Switch the unit 'off', and remove the wire between the two pins of the mains plug.

#### 2.1.2 Laser Safety

This unit employs a laser. Only qualified service personnel may remove the cover, or attempt to service this device (due to possible eye injury).

##### Laser Device Unit

Type	: Semiconductor laser GaAlAs
Wavelength	: 650 nm (DVD) 780 nm (VCD/CD)
Output Power	: 20 mW (DVD+RW writing) 0.8 mW (DVD reading) 0.3 mW (VCD/CD reading)
Beam divergence	: 60 degree

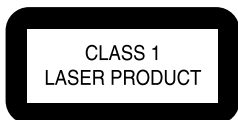



Figure 2-1

**Note:** Use of controls or adjustments or performance of procedure other than those specified herein, may result in hazardous radiation exposure. Avoid direct exposure to beam.

### 2.2 Warnings

#### 2.2.1 General

- All ICs and many other semiconductors are susceptible to electrostatic discharges (ESD, ). Careless handling during repair can reduce life drastically. Make sure that, during repair, you are at the same potential as the mass of the set by a wristband with resistance. Keep components and tools at this same potential. Available ESD protection equipment:
  - Complete kit ESD3 (small tablemat, wristband, connection box, extension cable and earth cable) 4822 310 10671.
  - Wristband tester 4822 344 13999.
- Be careful during measurements in the live voltage section. The primary side of the power supply (pos. 1005), including the heatsink, carries live mains voltage when you connect the player to the mains (even when the player is 'off!'). It is possible to touch copper tracks and/or components in this unshielded primary area, when you service the player. Service personnel must take precautions to prevent touching this area or components in this area. A 'lightning stroke' and a stripe-marked printing on the printed wiring board, indicate the primary side of the power supply.
- Never replace modules, or components, while the unit is 'on'.

#### 2.2.2 Laser

- The use of optical instruments with this product, will increase eye hazard.
- Only qualified service personnel may remove the cover or attempt to service this device, due to possible eye injury.
- Repair handling should take place as much as possible with a disc loaded inside the player.
- Text below is placed inside the unit, on the laser cover shield:

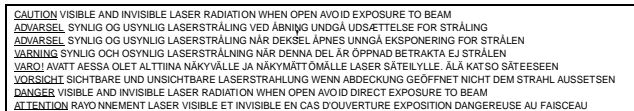

Figure 2-2

#### 2.2.3 Notes

##### Dolby

Manufactured under licence from Dolby Laboratories. "Dolby", "Pro Logic" and the double-D symbol are trademarks of Dolby Laboratories. Confidential Unpublished Works. ©1992-1997 Dolby Laboratories, Inc. All rights reserved.



Figure 2-3

##### Trusurround

TRUSURROUND, SRS and symbol (fig 2-4) are trademarks of SRS Labs, Inc. TRUSURROUND technology is manufactured under licence from SRS labs, Inc.



Figure 2-4

## 3. Directions for Use

### General Information

Since it is usual for DVD movies to be released at different times in different regions of the world, all Players have region codes and discs can have an optional region code. If you load a disc of a different region code to your Player, you will see the region code notice on the screen. The disc will not playback and should be unloaded.



Manufactured under license from Dolby Laboratories. "Dolby", "Pro Logic" and the double-D symbol are trademarks of Dolby Laboratories.

#### Laser safety

This unit employs a laser. Due to the risk of eye injury, only a qualified service person should remove the cover or attempt to service this device.

**USE OF CONTROLS OR ADJUSTMENTS OR PERFORMANCE OF PROCEDURES OTHER THAN THOSE SPECIFIED HEREIN MAY RESULT IN HAZARDOUS RADIATION EXPOSURE.**

**NOTE:**  
**PICTURES SHOWN MAY BE DIFFERENT BETWEEN COUNTRIES.**

#### LASER

Type	Semiconductor laser
Wave length	GaAlAs 650 nm (DVD) 780 nm (VCD/CD)
Output Power	7 mW (DVD) 10 mW (VCD/CD)
Beam divergence	60 degree

#### Important Note:

**Due to the numerous versions of new CD-Audio copy protection or enhanced CD-Audio protection recently available on certain discs, Philips is unable to guarantee that this DVD Player is fully compatible with such new discs. Should you have difficulty playing any such CD-Audio discs, kindly refer them to your CD-Audio disc retailer.**

**CAUTION**  
**(WARNING LOCATION: ON THE BACKPLATE OF THE SET)**

**NEVER MAKE OR CHANGE CONNECTIONS WITH THE POWER SWITCHED ON.**

The DVD VIDEO Player is in conformity with the EMC directive and low-voltage directive.



For Customer Use:

Read carefully the information located at the bottom of your DVD VIDEO Player and enter below the Serial No. Retain this information for future reference.

Model No. DVD VIDEO: 729/728  
Serial No. \_\_\_\_\_

### Introduction

Environmental Information	6
Supplied accessories	6
Safety Information	6
Symbols Used in this Manual	6

### Functional Overview

Front and Rear Panels	7
Remote Control	8

### Preparation

Basic Connection	9
Connecting to a TV	9
Connecting to an Audio System	10
Connecting to Optional Equipment	10
Inserting batteries into the Remote Control	11
Switching On	11
Smart Power: On/Off	11

### Operation

Basic Playback	12
General Operation	12
Video Control during playback	12
Audio Control during playback	12
Repeat	13
Repeat A-B	13
5 disc Resume	13
OSD (On-Screen-Display)	13
Zoom	13
Special DVD features	14
Playing a Title	14
Playing a Chapter	14
Camera Angle	14
Changing the Audio Language	14
Subtitles	14
Special VCD & SVCD Features	14-15
Playback Control (PBC)	14
Preview Function	15

### Picture CD & MP3 CD Playback

General Operation	16
MP3 & JPEG Navigator	16
Play Mode	16
Special JPEG Features	17
Function Introduction	17
Preview Function	17
Zoom picture	17

### Contents

Playback with multi-angles	17
Scan Effect	17
Special MP3 Features	17
Function Introduction	17
Playback Speed Control	17
JPEG and MP3 Simultaneous Playback	17

### Setup Menu

Basic Operation	18
General Setup menu	18-19
OSD Language	18
Program	18-19
Display Dim	19
Disc Lock	19
Screen Saver	19
Analogue Audio Setup menu	20-21
DOWNMIX	20
DRC	20
Sound Mode	20
Reverb Mode	21
Digital Audio Setup menu	21
Digital Output	21
LPCM Output	21

### Video Setup menu

TV Type	22
TV Display	22
Smart Picture	23
Colour Setting	23-24
Preference Setup menu	24-26
Audio Language	24
Subtitle Language	25
Disc Menu Language	25
Password	25
Parental Control	26
Default Setup	26
MP3/JPEG Navigator	26

### Digital Audio Setup menu

Digital Output	21
LPCM Output	21
Video Setup menu	22-24
TV Type	22
TV Display	22
Smart Picture	23
Colour Setting	23-24
Preference Setup menu	24-26
Audio Language	24
Subtitle Language	25
Disc Menu Language	25
Password	25
Parental Control	26
Default Setup	26
MP3/JPEG Navigator	26

### Preference Setup menu

Audio Language	24
Subtitle Language	25
Disc Menu Language	25
Password	25
Parental Control	26
Default Setup	26
MP3/JPEG Navigator	26

### Specifications

Specifications	27
----------------	----

### Maintenance

Maintenance	28
-------------	----

### Troubleshooting

Troubleshooting	28-29
-----------------	-------

## Introduction

Thank you for purchasing this Philips DVD Player. This Owner's Manual explains the basic operation of this DVD Player.

### Environmental Information

All unnecessary packaging has been omitted. We have tried to make the packaging easy to separate into three materials: cardboard (box), polystyrene foam (buffer) and polyethylene (bags, protective foam sheet).

Your DVD Player consists of materials which can be recycled and reused if disassembled by a specialised company. Please observe the local regulations regarding the disposal of packaging materials, exhausted batteries and old equipment.

### Supplied accessories

- DVD-Video Player
- Remote control with Batteries
- Owner's Manual
- Audio cable
- SCART cable

### Safety Information

- Before operating the DVD Player, check that the operating voltage indicated on the typeplate is identical with the voltage of your local power supply. If not, please consult your dealer.
- Place the DVD Player on a flat, hard and stable surface.
- There must be sufficient room in front of the player for the drawer to be opened.
- In a cabinet, allow about 2.5cm (1 inch) of free space all around the player for adequate ventilation.
- Do not expose your player to extremes of temperature or humidity.

## Functional Overview

### Front and Rear Panels

English

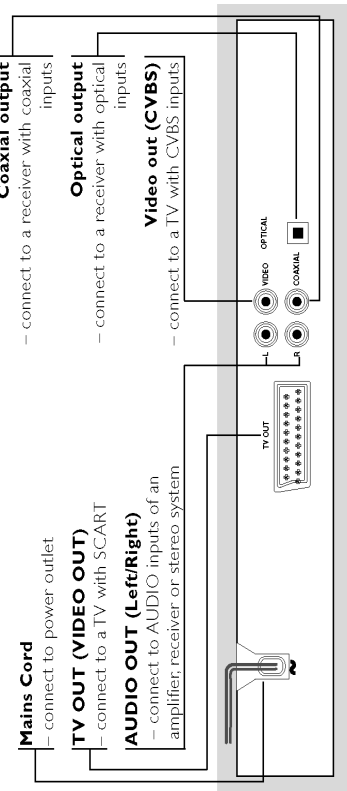
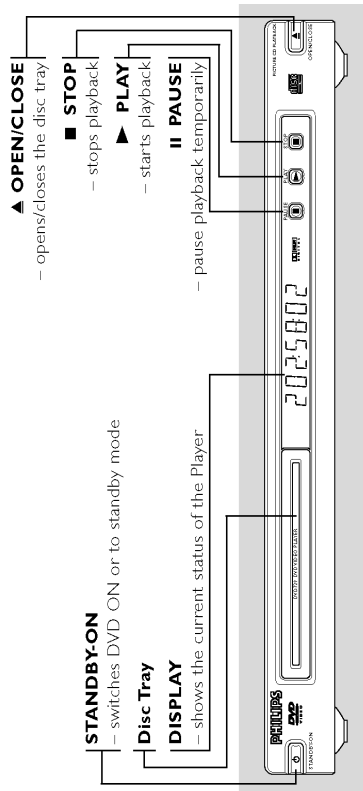

**Caution: Do not touch the inner pins of the sockets on the rear panel. Electrostatic discharge may cause permanent damage to the unit.**

- If the DVD Player is brought directly from a cold to a warm location, or is placed in a very damp room, moisture may condense on the lens of the disc unit inside the DVD Player. Should this occur, the DVD Player would not operate normally. Leave the power on for about one hour with no disc in the DVD Player until normal playback is possible.
- The mechanical parts of the set contain self-lubricating bearings and must not be oiled or lubricated.
- When the DVD Player is switched to Standby mode, it is still consuming some power. To disconnect the system from the power supply completely remove the AC power plug from the wall socket.

### Symbols Used in this Manual

The below symbols appear in some headings and notes with the following meanings:

	- Description refers to playback of DVD-video discs
	- Description refers to playback of Video CDs
	- Description refers to playback of Audio CDs
	- Description refers to playback of Super Video CDs

### Helpful Hints!

- **Some discs limit certain functions during playback (eg fast forward is not working at the beginning of certain discs). This is normal behaviour because the disc determines the way in which you can interact with its content.**

English

English

## Preparation

### Connecting to a TV

- 1 Connect the SCART (TV OUT) on the DVD Player to the corresponding connector (TV IN) on your TV.

**Note:**  
 – Ensure that the “TV” indication on SCART cable is connected to the TV set and “DVD” indication on SCART cable is connected to the DVD player.

If your TV is not equipped with a SCART input, you can select the following connection:

### If your TV has a CVBS Video input connector,

- 1 Connect the CVBS VIDEO OUT on the DVD Player to the CVBS VIDEO IN.
- 2 Connect the Left and Right AUDIO OUT on the DVD Player to the Left and Right AUDIO IN on the TV.

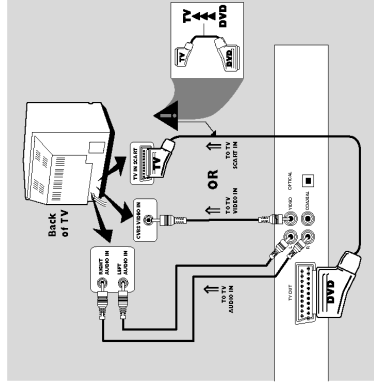

### Basic Connections

- Please refer to the instruction manuals of your TV/VCR, Stereo System or other devices as necessary to make the best connections.
- Make one of the following connections, depending on the capabilities of your existing equipment.

The following guidelines are options for the best picture and sound quality available on your DVD Player:

#### Picture

- 1 Use the CVBS Video Output for good picture quality.
- 2 Use SCART Output for best picture quality.

#### Sound

- 1 Digital audio connections provide the clearest sound. Connect the DVD Player's DIGITAL AUDIO OUT (COAXIAL or OPTICAL) to your amplifier or receiver.
- 2 If digital connections are not possible, connect the DVD Player's Left and Right (white and red) AUDIO OUT to your amplifier, receiver, stereo or TV.

#### Warning!

- Never make or change connections with the power switched on.
- Connect the DVD Player directly to your TV, instead of eg. a VCR, to avoid distortion because DVD video discs are copy protected.
- Do not connect the DVD Player AUDIO OUT to PHONO IN of your amplifier or receiver.

## Functional Overview

### Remote Control

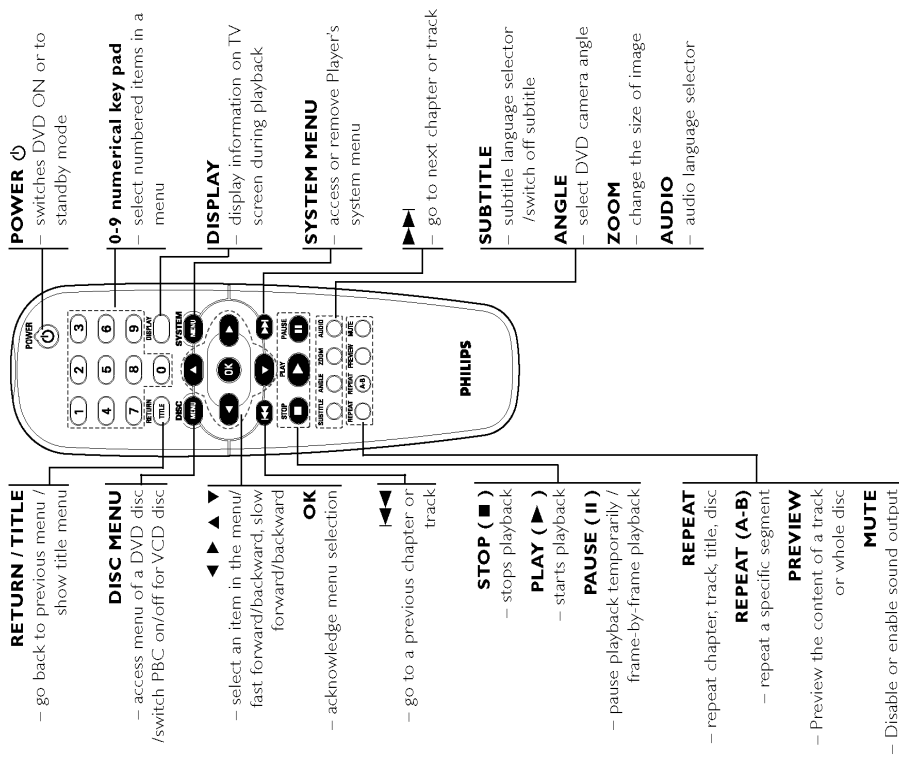

**Note:**  
 Press “STOP” for about 2 seconds to OPEN or CLOSE disc tray.

English

## Preparation

English

### Connecting to an Audio System

- 1 You can also listen to the sound of audio CDs and DVD video discs by connecting to an optional stereo system.
- 2 Connect the Left and Right AUDIO OUT on the DVD Player to the Left and Right AUDIO IN on the stereo system.

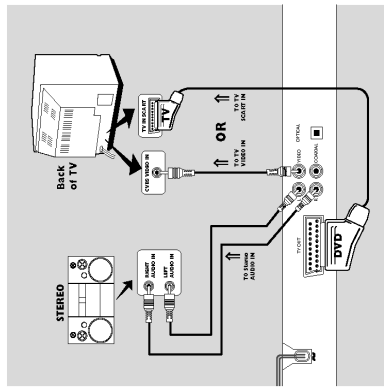

### Connecting to Optional Equipment

- A digital component with a built-in MPEG 2 or Dolby Digital™ decoder allows you to enjoy the surround sound while producing the effect of being in a movie theater or a concert hall. The Player outputs the surround sound signals from the DIGITAL OUT COAXIAL or OPTICAL connectors.

#### If your receiver has a MPEG 2 or Dolby Digital™ decoder,

- 1 Connect the COAXIAL or OPTICAL DIGITAL AUDIO OUT of the DVD Player to the COAXIAL or OPTICAL DIGITAL AUDIO IN on your receiver.

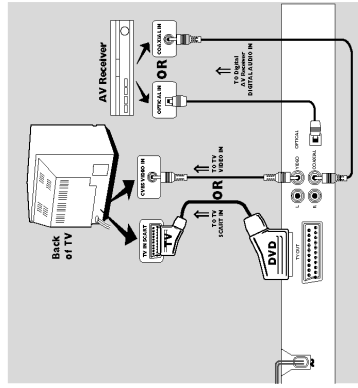

Notes:

- If the audio format of the digital output does not match the capabilities of your receiver, the receiver will produce a distorted sound or no sound at all.
- To see the selected audio format of the current DVD in the Setup Menu, refer to "Setup Menu".

## Preparation

English

### Switching On

- 1 Be sure that the DVD Player has been correctly connected to the TV and audio equipment.
- 2 Switch on the TV and DVD Player.
- 3 Set the TV to the correct Video In channel (eg. EXT1, EXT2, AV1, AV2, AUDIO/VIDEO, etc. Please refer to your TV owner's manual for details.)  
→ The Player display lights up and the default screen appears on the TV.
- 4 If you are using external equipment, (eg. audio system or receiver), turn it on and select the appropriate input source for the DVD Player output. Refer to the equipment owner's manual for detail.

### Smart Power On/Off

When in STOP or NO DISC mode, the DVD Player will switch to standby mode after 15 minutes without any operations for saving energy. It is easily reactivated by pressing the POWER or PLAY key on the remote control or the STANDBY-ON button on the front panel.

### Inserting batteries into the Remote Control

- 1 Open the battery cover by pressing in the tab, then lift off the cover.
- 2 Insert batteries with the correct polarity as indicated by the + and - symbols inside the battery compartment.
- 3 Close the cover.

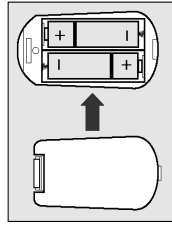

**CAUTION!**

- Remove batteries if they are exhausted or not to be used for a long time.
- Do not use old and new or different types of batteries in combination.
- Batteries contain chemical substances, so they should be disposed off properly and kept away from children.

### Using the Remote Control

- Direct the remote control at the remote sensor of the DVD Player.
- Do not drop or give the remote control a shock.
- Do not leave the remote control in extremely hot or humid places.
- Do not spill water or put anything wet on the remote control.

## Operation

### Basic Playback

- 1 Press **STANDBY-ON** on the front panel to turn on the DVD Player.
- 2 Press **OPEN/CLOSE** on the front panel to open disc loading tray.
- 3 Place the chosen disc in the tray, with the label facing up.
- 4 Press **OPEN/CLOSE** again to close the tray. → After recognizing this disc, the player begins to playback automatically.

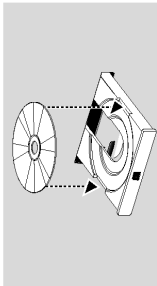

### Notes:

- DVDs may have a region code. Your player will not play discs that have a region code different from the region code of your Player.
- If 'Disc Lock' is set to **LOCK** and the disc inserted is not authorized, the 6-digit code must be entered and/or the disc must be authorized (see 'Disc Lock').

### General Operation

Note: All instructions set out below refer to the remote control, unless otherwise stated.

### Video Control during playback

- 1 **STOP/PLAY** **DVD** **VCD** **CD** **SVCD**  
If you press the **STOP** key once, you can later resume from the point at which you stopped by pressing the **PLAY** key. The player will start from the beginning of the disc if you pressed the **STOP** key twice.
- 1 **PAUSE/STEP** **DVD** **VCD** **CD** **SVCD**  
To get a still picture, press **PAUSE** key during playback.
- 2 To step forward to the next frame picture, press **PAUSE** key again.
- 3 To resume normal playback, press **PLAY**.
- 1 **SEARCH** **DVD** **VCD** **CD** **SVCD**  
To search the contents in fast speed, press the **or** **◀** for fast forward/backward searching.
- 2 Press the **◀** or **▶** again to increase the speed for searching.
- 3 Press **PLAY** to return to normal playback.

### SLOW MOTION **DVD**

- 1 To get a slow motion effect during playback press **▲** or **▼**.
- 2 Press **▲** or **▼** again, you can get different playback forward/backward speeds.
- 3 Press **PLAY** to return to normal play back.

### **VCD** **SVCD**

- 1 To get a slow motion effect during playback, press **▼**.
- 2 Press **▼** again, you can get different playback forward speeds.
- 3 Press the **PLAY** key to return to normal play back.

### Note:

- The **SLOW BACKWARD** function is not available for **Super VCD/VCD/CD** discs.

### Audio Control during playback

- 1 **MUTE** **DVD** **VCD** **CD** **SVCD**  
Press the **MUTE** key to disable the sound output.
- 2 Press the **MUTE** key again to deactivate mute.

### Audio Channel Selection

#### **VCD** **CD** **SVCD**

- 1 **Super VCD** has two stereo audio channels which are used for playing karaoke or the audio language selection. (For instance, you can choose one channel for only the music background of the song while you play the karaoke.)  
Press the **AUDIO** key on the remote control to select the audio channels you want.
- 2 **VCD** has only one stereo audio channel, you can select **STEREO**, **LEFT MONO**, **RIGHT MONO** or **MIX-MONO** by pressing the **AUDIO** key on the remote control.
- 3 **STEREO**: Output the left and right audio channels of the disc through the left and right audio sockets accordingly.  
→ **LEFT MONO**: Output the left audio channels of the disc through the left and right audio sockets.  
→ **RIGHT MONO**: Output the right audio channels of the disc through the left and right audio sockets.  
→ **MIX-MONO**: each of the audio sockets can output the same audio effect as stereo.

### Note:

- If you choose **digital audio output** and set **DIGITAL OUTPUT** to **ALL**, you can not select **LEFT MONO** and **RIGHT MONO** by **AUDIO** key.

## Operation

### OSD (On-Screen Display)

#### **DVD** **VCD** **SVCD**

- This function will provide some information about your playing disc on the screen.
- Press **DISPLAY** key on the remote control.

### Title Selection

- 1 Press **◀▶** to highlight option Title number.
- 2 Press **▲▼** to change the title number.  
→ **DVD** Player will playback selected title.

### Chapter Selection

- 1 Press **◀▶** to highlight option chapter number.
- 2 Press **▲▼** to change the chapter number.  
→ **DVD** Player will playback selected chapter.

### Time Search

- Press **◀▶** to highlight time display area.  
For **DVD** discs:  
→ **CC** refers to the elapsed time of the current chapter. **CR** refers to the remaining time of the current chapter. **TC** refers to the elapsed time of the current title. **TR** refers to the remaining time of the current title.

### For Super VCD or VCD disc.

- **DC** refers to the elapsed time of the current disc. **DR** refers to the remaining time of the current disc. **TC** refers to the elapsed time of the current track. **TR** refers to the remaining time of the current track.

### Press **▲** to make the selection.

- Press the **◀▶** keys to highlight the item **TIME** and you can play from any point of the disc.  
→ Enter hours, minutes and seconds from left to right in the time edit box using remote control numerical key pad. (e.g. 0:34:27)  
→ Press the **OK** key to confirm.

### Zoom **DVD** **VCD** **SVCD**

The Zoom function allows you to change the image size.

- 1 Press the **ZOOM** key to activate the function.  
→ Use the **◀▶** key to view other parts of the zoomed picture.  
→ Playback will continue.
- 2 Press the **ZOOM** key repeatedly to return to the original size.

### Note:

- The function is **NOT** available for some **DVD** discs.



Operation

English

Special DVD Features

Playing a Title DVD

A DVD disc may have one or more titles. This depends on the content (a movie, video clips, a drama series, etc.) on the disc.

- After you load a disc, information about the content shows on the screen, waiting for your selection. You can also press the TITLE key on the remote control to turn back to the title menu during playback.
- 1 Press the appropriate numerical key or ▲▼◀▶ keys on the remote control to highlight your selection.
- 2 Press the OK key to confirm.

Playing a Chapter DVD

When you have selected a title, it may include one or more chapters.

- Any time you want to watch another chapter during playback, press DISC MENU key to turn back to the chapter menu (if disc has chapter menu).
- 1 Press the appropriate numerical key or ▲▼◀▶ keys on the remote control to highlight your selection.
- 2 Press the OK key to confirm.
- 3 After a chapter has been selected, you also can press the ◀◀ or ▶▶ key to make a change.

Camera Angle DVD

Some discs contain scenes which have been shot simultaneously from various angles. This DVD player allows you to select the desired camera angle.

- Press the ANGLE key on your remote control.
- Note:
  - The function is available only for the DVD discs which have several angles recorded.

Changing the audio language DVD

- Press AUDIO repeatedly to select the different languages.

Note:
 

- The function will be activated only if the DVD is recorded with multi-language audio tracks.

Subtitles DVD SVCD

- 1 Press SUBTITLE repeatedly to select the different subtitles.
- 2 Press SUBTITLE for about 2 seconds to switch subtitle on or off.

Note:

- The function will be activated, only if the DVD or SuperVCD is recorded with multi-subtitles.

Special VCD & SVCD Features

Playback Control (PBC)

PBC function allows you to enter the index menu which is used to select a track after loading the VCD & SVCD disc.

If you want to activate the function during the playback or after pressing the STOP key twice.

- 1 Press the DISC MENU key on the remote control to set the PBC On.
- 2 Pay attention to the hint on the screen. Use the ◀◀ or ▶▶ key to select the page you like.
  - If the items of the index menus are numbered, press the appropriate numerical key on the remote control.
- 3 Press the RETURN key to enter the index menu during the playback.

Notes:

- The content of the index menu depends on the disc. Please refer to the disc's instructions for details.
- If the disc doesn't include the PBC information, this function will have no effect.

If you want to skip the index menu and playback directly from the beginning.

- Press the DISC MENU key on the remote control to switch off the function.

Preview Function

- Press the PREVIEW key to enter previewing menu.
- Press ▲▼ key to highlight TRACK DIGEST, DISC INTERVAL or TRACK INTERVAL.
- Press OK key to open one option.



- After you enter the menu of any digest type,
  - To quit preview function: Press ▲▼◀▶ to highlight EXIT and press OK to confirm.
  - To return to the previewing menu for selecting the other digest type: Press ▲▼◀▶ to highlight MENU and press OK to confirm.

1. Track Digest

This function will minimize the picture of every track in order to display every six of these tracks on the screen to help you know the content of every track on the disc.



- To choose the desired track, please press ▲▼◀▶ to highlight the second line and input your selected track number next to "SELECT".
- Select the others from the current six by pressing the ◀◀ or ▶▶ key to open the previous or next page.
- Press the OK key to confirm.

2. Disc Interval

This function is used to divide a disc into six parts by regular intervals and display them on one page to help you preview the whole disc.



- To choose the desired track, please press ▲▼◀▶ to highlight the second line and input your numerical selection next to "SELECT".
- Press the OK key to confirm.

3. Track Interval

This function is used to divide a single track into six parts by regular intervals and display them on one page to help you preview the selected track.



- To choose the desired track, please press ▲▼◀▶ to highlight the second line and input your numerical selection next to "SELECT".
- Press the OK key to confirm.

Operation

English

## Picture CD & MP3 CD Playback

- This Player can playback JPEG format pictures and MP3 files on a personally recorded CD-R/RW, disc, or commercial CD.
- Playback pictures or songs one by one automatically.
- Album and track selection.
- Repeat (disc / album / track / picture).
- Select any music or pictures from the disc to playback them together.
- Maximum number of files within one folder is 500.
- Maximum files Programmable is 100.
- MP3: Maximum supported Bitrate is 25.6kbits or 48kHz in Variable Bitrate mode.
- JPEG: Maximum supported resolution is 3072x2048 (for baseline JFG pictures), or 2000x1500 (for progressive JFG pictures).

### General Operation

- If you choose WITH MENU in the Setup Menu (Please refer to the MP3 & JPEG navigator below), the Picture CD/MP3 CD menu will be shown on the screen before playback.
- 
- At any time during playback, press DISC MENU to return to the menu for Selection/Repeat / Shuffle / Single playback.
  - Both columns on every page of the menu contain six files or folders, you can press ◀▶ to highlight either of the column, and then press ▶▶ or ◀◀ to open the next or previous six files or folders.

### MP3 & JPEG Navigator

- To select a different playback method, follow the steps below.
- At STOP mode, press the SYSTEM MENU key to open the setup menu.
  - Press the ◀▶ key to highlight PREFERENCE.
  - Press OK to open the PREFERENCE menu.
  - Press the ◀▶ key to highlight the MP3/JPEG NAV menu.
  - Press the ◀▶ key to enter the menu.
  - Press the ◀▶ key to highlight the NO MENU or WITH MENU item.
  - WITHOUT MENU: automatically playback all files in according date sequence.
    - WITH MENU: playback files in the selected folder.
  - Press the OK key to confirm your selection.

### Play Mode

#### Auto Playback

If you choose WITHOUT MENU, the DVD Player will automatically playback Picture CD/MP3 CD in sequence when it is loaded.

#### Playback Selection

- One way is to press the number of your favourite file at any time during playback.
  - Another way is to select via the menu (after pressing STOP).
- Press DISC MENU to open the Picture CD/MP3 CD menu.
  - When the menu appears on the screen, press the ◀▶ key to select the folder you want and press the OK to open it.
  - Press the ▶▶ to enter the file list.



- Press the ◀▶ key to highlight one option, or press its number.
  - ▶▶ or ◀◀ to go to the next or previous page.
  - Press OK key to confirm.
  - The playback will start from this selected file to the last in this folder.
- Repeat / Shuffle / Single Playback
  - When the Picture CD/MP3 CD menu is shown on the screen, Press REPEAT key repeatedly, the button beside PLAY MODE will display different option.
  - SINGLE: The file plays once.
  - REPEAT ONE: For JPEG files, the current picture remains on the screen. For MP3 music, the selected song plays repeatedly.
  - REPEAT FOLDER: All files in the folder play repeatedly.
  - SHUFFLE: All files are played randomly.
- If you press REPEAT key during playback, the option will be displayed on the screen accordingly.

#### Program Playback

- When the Picture CD/MP3 CD menu is shown on the screen, Press DISC MENU key.
  - The left column is the original files and the right one is the programmed files.

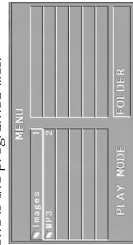

- Press the ◀▶ to select one file.
  - ▶▶ or ◀◀ to open the next six files to choose.
- Press OK or PLAY key to add the selected file from the left column to the right column.
  - The maximum is 100 files.
- Press STOP key to remove the programmed file from the right column.
- Highlight one file of the right column and press OK key, then the programmed files will start playing back.

### Special JPEG Features

#### Function Introduction

Picture CD is a disc with a collection of JPEG format pictures, and all extension filenames should end with 'JPG'. The CD can be recorded on any computer, and pictures may be from digital camera or scanner. If the customers prefer, they can make this CD become a Digital Album. You can choose any general function introduced in GENERAL OPERATION, besides, you also can, Display the thumbnails of 12 pictures.

- Zoom the picture.
- Rotate the picture.
- Flip the picture vertically or horizontally.
- Scan pictures by different effects.

#### View Function

This function shows the content of the current folder or the whole disc. Press the STOP key during playback of JPEG pictures. You will see the thumbnails of 12 pictures on the screen.



- Press ▶▶ or ◀◀ key to display the other pictures on the next or the previous page.
- Press the ◀▶ key to highlight one of them and press OK to playback or; Move the cursor to highlight SLIDE SHOW on the bottom of the page to start playback from the first picture on the current page.
- Press DISC MENU to go to the Picture CD/MP3 CD menu.

#### Zoom picture

- During playback, press ZOOM key to display the picture with different scales.
- Press the ◀▶ key to view the rest of the zoomed picture.

## Picture CD & MP3 CD Playback

- Playback with multi-angle**
  - When displaying one picture on TV screen you can press ▶▶ or ◀◀ to get different effects.
  - key: Flip the picture vertically.
  - key: Flip the picture horizontally.
  - key: rotate the picture anti-clockwise.
  - key: rotate the picture clockwise.

### Scan Effect

- Press ANGLE key repeatedly to choose different scan effects.

### Special MP3 Features

#### Function Introduction

"MP3" stands for "MPEG Audio Layer 3", and is a part of the MPEG standard. A CD can store up to 10 hours of MP3 audio, which is nearly 10 times as much as an Audio CD. Each song is recorded as a file. You can choose any general function introduced in GENERAL OPERATION. You can also choose different playback speeds.

#### Playback Speed Control

- Press RETURN/TITLE key to switch to MP3+NAV mode.
- Press ◀▶ you can get different playback backward/forward speeds.
- You also can press ▶▶ or ◀◀ to change the tracks.

### JPEG and MP3 simultaneous playback

- Firstly playback MP3 music according to the instructions introduced in playback Selection.
- Please switch to MP3+JPEG+NAV by pressing RETURN/TITLE.
- Then select a picture to playback. Please refer to the instructions introduced in playback Selection.
  - Now the pictures will be played back in sequence together with MP3 music.
- To quit simultaneous playback, press DISC MENU key to return to the Picture CD/MP3 CD menu, then pictures will be stopped. After that, press STOP key, then MP3 music will be stopped as well.

#### Note:

- In the function of JPEG and MP3 Simultaneous Playback, ▶▶ and ◀◀ keys are invalid for MP3.

## Setup Menu

English

### Basic Operations

- 1 Press SYSTEM MENU in the STOP mode to enter the Setup Menu.
- 2 Press the OK key to go to the next level submenu or confirm your selection.
- 3 Press the ◀▶ keys to enter the submenu or return to the previous menu.
- 4 Press the ▲▼ keys to highlight the desired menu.
- 5 Press SYSTEM MENU to quit the setup menu.
  - When you quit the setup menu, the settings will be stored in the player's memory even if the player is switched to power off.

### General Setup menu

Some settings need to be made in this menu. They are: OSD LANGUAGE, PROGRAM, DISPLAY DIM, DISC LOCK, and SCREEN SAVER.

Follow the steps below:

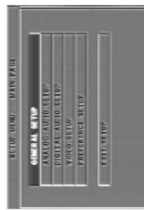

- 1 Press the SYSTEM MENU key to enter the setup menu.
- 2 Press the ▲▼ keys to choose the GENERAL SETUP.
- 3 Press the OK key to confirm selection.

### OSD language

This option is to select a language for information displayed on TV screen.

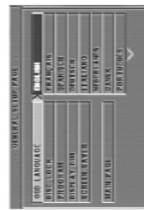

- 1 Press the ▲▼ keys to highlight OSD LANGUAGE in the GENERAL SETUP menu.
- 2 Enter its submenu by pressing the ▶ key.
- 3 Move the cursor by pressing the ▲▼ keys to highlight the selected language.
- 4 Press the OK key to confirm.
- 5 Press the ◀ key to return to the GENERAL SETUP menu.

### Program (not for Picture CD/MP3)

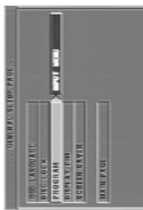

- 1 To choose PROGRAM, press ▲▼ keys.
- 2 Press the ▶ key to move the cursor to the field of the submenu to choose the item ON.
- 3 Press OK to enter the programme page.



- 1 **Input your favourite track**  
Input valid track number by pressing the numerical keys.
- 2 Press the ◀▶ keys to move the cursor to the next selected position.
  - If the track number is more than ten, press ▶▶ to open the next page and go on programming, or press ◀▶▶ to highlight NEXT button, and then press OK.
- 3 Repeat this steps to input another track number until the whole programme is completed.

### Remove a track

- 1 Press the ◀▶▶ keys to move the cursor to the track you want to remove.
- 2 Press OK or PLAY key to remove this track from the programme menu.

### Playback tracks

- 1 When programming is completed, Press the ◀▶▶ keys to move the cursor to the START button.
- 2 Press OK.
  - DVD Player will playback the selected tracks under the programmed sequence.

### Quit the program playback

- 1 In the PROGRAM menu, Press the ◀▶▶ keys to move the cursor to the EXIT button.
- 2 Press the OK key to quit this menu.

## Setup Menu

English

- 1 Press the ▲▼ keys to highlight DISC LOCK in the GENERAL SETUP menu.
- 2 Enter its submenu by pressing the ▶ key.
  - LOCK: Lock the disc being played.
  - UNLOCK: unlock the disc.
- 3 Press the ◀ key to return to the GENERAL SETUP menu.

### Notes:

- When a locked disc is loading, the DVD Player will prompt you to enter your password (842 100 is the default password).
- To change the password, refer to the option PASSWORD in the PREFERENCE SETUP menu.

### Screen Saver

This function is used to turn the screen saver on or off.

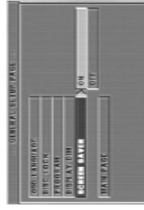

- 1 Press the ▲▼ keys to highlight SCREEN SAVER in the GENERAL SETUP menu.
- 2 Enter its submenu by pressing the ▶ key.
- 3 Move the cursor by pressing the ▲▼ keys to highlight the selected item.
  - ON: In STOP or No DISC mode, if no actions are performed within 5–6 minutes, the screen saver will be activated.
  - OFF: Screen saver is disabled.
- 4 Press OK to confirm.
- 5 Press the ◀ key to return to the GENERAL SETUP menu.

### Stop the program playback

During playback of the programmed tracks, press STOP key. Then after you press PLAY key, the DVD Player will resume normal playback.

### Repeat the program playback

During playback of the programmed tracks, press the REPEAT key. The programmed tracks can be played again.

### Display Dim

This function is used to adjust the brightness of display on the front panel of the DVD Player.

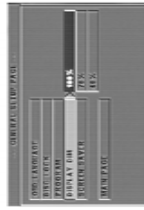

- 1 Press the ▲▼ keys to highlight DISPLAY DIM in the GENERAL SETUP menu.
- 2 Enter its submenu by pressing the ▶ key.
  - Press the ▲▼ keys to highlight 100%/70%/40% item.
- 3 Press OK to confirm.
- 4 Press the ◀ key to return to the GENERAL SETUP menu.

### Disc Lock

When the disc is locked, the player will store its specific code into the memory for future identification. For the next playback, the DVD Player will prompt you to enter the password. Then, press OK to load the disc.

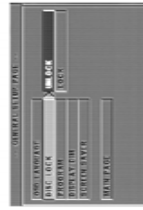

- 1 Press the ▲▼ keys to highlight SCREEN SAVER in the GENERAL SETUP menu.
- 2 Enter its submenu by pressing the ▶ key.
- 3 Move the cursor by pressing the ▲▼ keys to highlight the selected item.
  - ON: In STOP or No DISC mode, if no actions are performed within 5–6 minutes, the screen saver will be activated.
  - OFF: Screen saver is disabled.
- 4 Press OK to confirm.
- 5 Press the ◀ key to return to the GENERAL SETUP menu.

## Setup Menu

English

### Analogue Audio Setup menu

This menu contains setup options for your analog audio output, such as DOWNMIX, D.R.C. (Dynamic Range Compression), Sound Mode and Reverb Mode etc, which makes the setup system reproduce high quality surround sound.

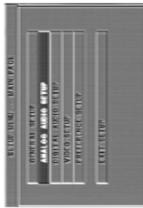

- 1 Press SYSTEM MENU.
- 2 Press the **▲▼** keys to highlight the ANALOG OUTPUT SETUP.
- 3 Press OK to confirm.

### DOWNMIX mode

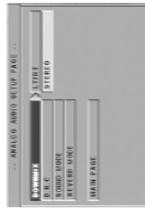

- 1 Press the **▲▼** keys to highlight the DOWNMIX.
- 2 Enter its submenu by pressing the **▶** key.
- 3 Move the cursor by pressing the **▲▼** keys to highlight the selected item.
- L/R/T
- This option should be used only if your DVD Player is connected to a Dolby Prologic decoder:
  - STEREO
  - This option will downmix Dolby Digital signals directly into analogue stereo from L/R sockets.
- 4 Press OK.
- 5 Press the **◀** key to return to the ANALOG OUTPUT SETUP menu.

### D.R.C. (Dynamic Range Compression)

The DVD Player will compress the dynamic range of its sound output for late-night listening.

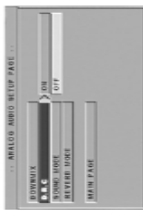

- 1 Press the **▲▼** keys to highlight D.R.C.
- 2 Enter its submenu by pressing the **▶** key.
- 3 Move the cursor by pressing the **▲▼** keys to highlight the selected item.
  - ON: Enable D.R.C.
  - OFF: Disable D.R.C.
- 4 Press OK.
- 5 Press the **◀** key to return to the ANALOG OUTPUT SETUP menu.

### Sound Mode

The SOUND MODE allows you to select from various preset mode that control the sound frequency to optimize certain musical styles. It greatly enhances the excitement and enjoyment of your favourite music.



- 1 Press the **▲▼** keys to highlight the SOUND MODE.
- 2 Enter its submenu by pressing the **▶** key.
- 3 Move the cursor by pressing the **▲▼** keys to highlight the selected item.
  - OFF: Playback a disc in original sound effect.
- 4 Press OK.
- 5 Press the **◀** key to return to the DIGITAL OUTPUT SETUP menu.

## Setup Menu

English

- 1 Press the **▲▼** keys to highlight DIGITAL OUTPUT.
- 2 Enter its submenu by pressing the **▶** key.
- 3 Press the **▲▼** keys to highlight the selected item.
  - ALL: Original digital signals output.
  - PCM ONLY: If your receiver is PCM-compatible, or your receiver can not decode MPEG-2, Dolby Digital, or DTS audio, choose this option.
- 4 Press OK.
- 5 Press the **◀** key and return to the DIGITAL OUTPUT SETUP menu.

**Note:**  
 – If DIGITAL OUTPUT is set to ALL, all audio settings except MUTE are invalid.

### LPCM Output

If you connect the DVD Player to a PCM compatible receiver via the digital terminals, such as coaxial or optical etc, you may need to adjust LPCM OUTPUT.

Discs are recorded at a certain sampling rate. The higher the sampling rate, the better the sound quality.

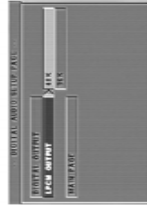

- 1 Press the **▲▼** keys to highlight the LPCM OUTPUT.
- 2 Enter its submenu by pressing the **▶** key.
- 3 Move the cursor by pressing the **▲▼** keys to highlight the selected item.
  - 48K: Playback a disc recorded at the sampling rate of 48kHz.
  - 96K: Playback a disc recorded at the sampling rate of 96kHz.
- 4 Press OK.
- 5 Press the **◀** key to return to the DIGITAL OUTPUT SETUP menu.

### Reverb Mode

The REVERB MODE can stimulate the echo and frequency response of some particular places to make you feel like personally on the place.

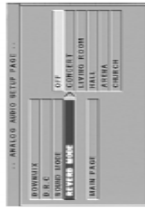

- 1 Press the **▲▼** keys to highlight the REVERB MODE.
- 2 Enter its submenu by pressing the **▶** key.
- 3 Move the cursor by pressing the **▲▼** keys to highlight the selected item.
  - OFF: Playback a disc in original sound effect.
- 4 Press OK.
- 5 Press the **◀** key to return to the DIGITAL OUTPUT SETUP menu.

### Digital Audio Setup menu

In this menu, you can set up the digital audio output signal from the digital terminals, such as coaxial or optical etc.

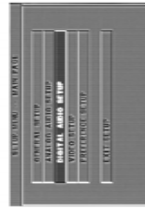

- 1 Press SYSTEM MENU to enter the SETUP menu.
- 2 Press the **▲▼** keys to choose the DIGITAL OUTPUT SETUP.
- 3 Press OK.

### Digital Output

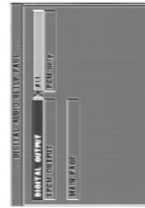

## Setup Menu

### Video Setup menu

There are items included in VIDEO SETUP menu such as TV TYPE, TV DISPLAY, SMART PICTURE, COLOR SETTING.

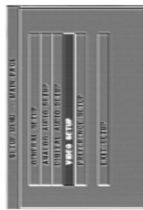

- 1 Press STOP.
- 2 Press SYSTEM MENU to enter the menu.
- 3 Highlight VIDEO SETUP by pressing the **▲▼** keys.
- 4 Press OK.

### TV Type

Before viewing the DVD or VCD, ensure that the PAL or NTSC setting of the system matches your TV set.



- 1 Press the **▲▼** keys to highlight TV TYPE in the VIDEO SETUP menu.
- 2 Enter its submenu by pressing the **▶** key.
- 3 Move the cursor by pressing the **▲▼** keys to highlight one option.
- 4 Press OK.
- 5 Press the **◀** key to return to the VIDEO SETUP menu.

### NTSC/PAL Conversion

This player is equipped with a NTSC/PAL conversion feature to convert the video output of the disc to match your TV system. The conversions supported are as below:

Type	Disc Format	Output format	
		Selected mode	AUTO
DVD	NTSC	NTSC	NTSC
	PAL	PAL	PAL
VCD	NTSC	NTSC	NTSC
	PAL	NTSC	PAL

- Notes:
- MULTI can only be selected when using a TV that has both the NTSC and PAL systems.
  - If you have a multi-standard TV (PAL/NTSC), use the MULTI setting to obtain the best picture quality.

### TV Display

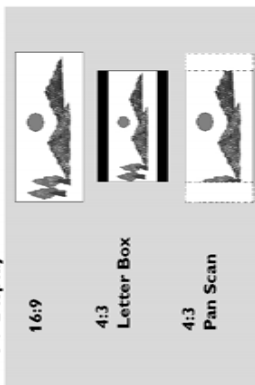

Select the aspect ratio of the TV to be connected.

- 16:9 **→** when you connect a wide-screen TV to the DVD Player.
- 4:3 **LETTERBOX** **→** when you connect a normal TV to the DVD Player: Displays a wide picture with bands displayed on the upper and lower portions of the TV screen.
- 4:3 **PANSCAN** **→** when you connect a normal TV to the DVD Player: Displays the wide picture on the whole TV screen with a portion automatically cut off.



- Setup the item as follows.
- 1 Press the **▲▼** keys to highlight the TV DISPLAY option in the VIDEO SETUP menu.
  - 2 Enter its submenu by pressing the **▶** key.
  - 3 Move the cursor by pressing the **▲▼** keys to highlight the selected item.
  - 4 Press OK.
  - 5 Press the **◀** key to return to the VIDEO SETUP menu.

- Note:
- PanScan output is not available on all discs.

## Setup Menu

English

### Color Setting

In this menu you can personalise the picture color by adjusting brightness, contrast, hue and saturation.

- 1 Press the **▲▼** keys to highlight COLOR SETTING in the VIDEO SETUP menu.
- 2 Press OK to open its submenu.

### Brightness



- 1 Press the **▲▼** keys to highlight BRIGHTNESS in the COLOR SETTING menu.
- 2 Press the **▶** key to open the level bar; **→** Display at the bottom of the screen.
- 3 Press the **▶◀** keys to increase and decrease the brightness level.
- 4 Press the **▲▼** or **OK** key to return to the COLOR SETTING menu.

### Smart Picture

In this menu, you can choose a picture setting from a fixed set of ideal predefined picture settings.



- 1 Press the **▲▼** keys to highlight SMART PICTURE in the VIDEO SETUP menu.
- 2 Press the **▶** key to highlight the item of the submenu.
- 3 Press the **▲▼** keys to choose an item. **→** STANDARD: select a standard picture setting. **→** BRIGHT: make the TV picture brighter. **→** SOFT: make the TV picture softer. **→** PERSONAL: achieve the color effect set in the COLOR SETTING menu.
- 4 Press OK.
- 5 Press **◀** key to return to the VIDEO SETUP menu.

## Setup Menu

English

### Contrast

- 1 Press the **▲▼** keys to highlight **CONTRAST** in the **COLOR SETTING** menu.
- 2 Press the **▶** key to open the level bar.
- 3 Press the **▶◀** keys to increase and decrease the contrast level.
- 4 Press the **▲▼** or **OK** key to return to the **COLOR SETTING** menu.

### Hue

- 1 Press the **▲▼** keys to highlight **HUE** in the **COLOR SETTING** menu.
- 2 Press the **▶** key to open the level bar.
- 3 Press the **▶◀** keys to increase and decrease the hue level.
- 4 Press the **▲▼** or **OK** key to return to the **COLOR SETTING** menu.

### Saturation

- 1 Press the **▲▼** keys to highlight **SATURATION** in the **COLOR SETTING** menu.
- 2 Press the **▶** key to open the level bar.
- 3 Press the **▶◀** keys to increase and decrease the saturation level.
- 4 Press the **▲▼** or **OK** key to return to the **COLOR SETTING** menu.

### Preference Setup menu

There are options included in **PREFERENCE** menu such as **AUDIO**, **SUBTITLE**, **DISC MENU**, **PARENTAL**, **PASSWORD**, **DEFAULT** and **MP3/PEG-NAV**.

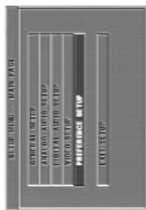

- 1 Press the **STOP** key twice.
- 2 Press **SYSTEM MENU** to enter the menu.
- 3 Highlight the **PREFERENCE SETUP** by pressing the **▲▼** keys.
- 4 Press **OK** to confirm your selection.

### Audio language

DVD discs are available with multiple audio languages. Use this option to select the preferred default audio language.

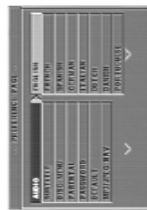

- 1 Press the **▲▼** keys to highlight **AUDIO**.
- 2 Enter the submenu by pressing the **▶** key.
- 3 Move the cursor by pressing the **▲▼** keys to highlight the selected option.
- 4 Press **OK**.
- 5 Press the **◀** key to return to the **PREFERENCE** menu.

**Note:**

- Your DVD disc may not include the audio language which you set in the **AUDIO** menu. If so, the player will use another audio language instead.

### Subtitle language

DVD discs are available with multi-subtitle languages. Use this option to select the preferred default subtitle language.

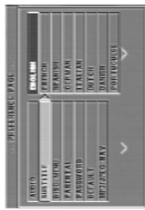

- 1 Press the **▲▼** keys to highlight **SUBTITLE**.
- 2 Enter the submenu by pressing the **▶** key.
- 3 Move the cursor by pressing the **▲▼** keys to highlight the selected option.
- 4 Press **OK**.
- 5 Press **◀** key to return to the **PREFERENCE** menu.

**Note:**

- Your DVD disc may not include the subtitle which you set in the **SUBTITLE** menu. If so, the player will use another subtitle language instead.

### Disc Menu language

DVD discs are available with multiple disc menu languages. This option is used to select the default disc menu language.

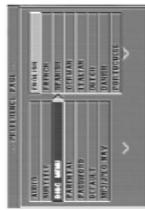

- 1 Press the **▲▼** keys to highlight **DISC MENU**.
- 2 Enter the submenu by pressing the **▶** key.
- 3 Move the cursor by pressing the **▲▼** keys to highlight the selected item.
- 4 Press **OK**.
- 5 Press **◀** key to return to the **PREFERENCE** menu.

**Note:**

- If your DVD disc doesn't include the disc menu language you have set, the player will use another recorded language instead.

## Setup Menu

English

### If you choose OTHERS in AUDIO, SUBTITLE or DISC MENU menu,

You can select other languages. Please do as follows.

- 1 Move the cursor by pressing the **▲▼** keys to highlight **OTHERS**.
- 2 Press **OK**.
- 3 → The DVD Player will prompt you to enter a language code (four digits).  
Input a language code by pressing numerical keys.
- 4 → Please look up the preferred language code in the chapter **LANGUAGE CODE**, which can be found at the end of this manual.

### Password

This item is used for the parental control and disc lock. Enter your six digit password when a hint is displayed on the screen.

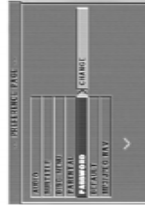

- 1 Press the **▲▼** keys to highlight the **PASSWORD** option.
- 2 Enter the submenu by pressing the **▶** key.
- 3 Press **OK** key to open the **PASSWORD CHANGE** page.



- 4 Enter the current 6 digit code.
- 5 If successful, the Player will prompt for a new one.
- 6 After that, enter the new password again to reconfirm.
- 7 Press the **OK** key to return to the **PREFERENCE** menu.

→ The new 6 digit code will take effect.

**Notes:**

- You can change the setup of parental control and load a locked disc with a valid password being entered.
- If you forget your password, you can enter the default password 842100.

## Setup Menu

### Parental Control **DVD**

Movies on DVDs may contain scenes which are not suitable for children. Therefore, discs may contain 'Parental Control' information which applies to the complete disc or to certain scenes on the disc. These scenes are rated from 1 to 8, and alternative, more suitable scenes are available on the disc. Ratings are country dependent. The 'Parental Control' feature allows you to prevent discs from being played by your children or to have certain discs played with alternative scenes.

- VCD, SVCD, CD have no level indication, so parental control function has no effect on those kinds of discs. This applies to most illegal DVD discs.
- You can follow the steps below to setup the parental control:

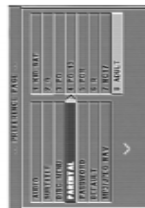

- 1 Press the **▲** keys to highlight PARENTAL.
- 2 Move to its submenu by pressing the **▶** key.
- 3 Then use the **▲**/**▼** keys to highlight a rating for the disc inserted.
- 4 Press OK to confirm, then press the **◀** key to return to the PREFERENCE menu.

### No Parental Control

Parental Control is not activated. The Disc will be played in full.

- 1 Select ADULT item.
- 2 Press OK.

### Ratings 1 to 7:

Some discs contain scenes which are not suitable for children. All scenes with a rating higher than you set will be skipped during playback. However if the disc contains alternate scenes, these will play automatically. If not, the playback will stop and the six digits code will need to be entered again.

### Default Setup

If problems occur while setting up the DVD Player the DEFAULT function can be used to reset all options to the factory defaults and all your personal settings will be erased.

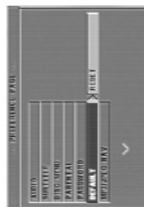

- 1 Press **▲**/**▼** to highlight DEFAULT.
- 2 Highlight RESET by pressing the **▶** key.
- 3 Press OK.

**CAUTION:**  
 – When this function is activated, all setups will be reset to factory defaults.

### MP3/JPEG Navigator

This menu allows you to select alternate settings when you playback picture CD and MP3 CD.



- 1 Press **▲**/**▼** to highlight MP3/JPEG NAV.
- 2 Press **▶** to enter the submenu.
- 3 Press **▲**/**▼** to highlight WITHOUT MENU or WITH MENU.  
 → WITHOUT MENU: playback all pictures or MP3 music in sequence automatically.  
 → WITH MENU: playback pictures or MP3 music in the selected folder.
- 4 Press OK key to confirm your selection.

## Specifications

PLAYBACK SYSTEM	AUDIO PERFORMANCE
DVD/Video	24bit
Video CD & SVCD	fs 96 kHz
CD	4Hz- 44kHz
PICTURE CD	fs 48 kHz
MP3-CD	4Hz- 22kHz
CD-R, CD-RW	fs 48 kHz
DVD+R, DVD+RW	fs 44-1kHz
TV STANDARD (PAL/50Hz) (NTSC/60Hz)	fs 44-1kHz
Number of lines	105 dB
Playback	6.25 Multistandard (PAL/NTSC)
VIDEO PERFORMANCE	Dynamic range (1kHz)
CVBS	1Vpp — 75
RGB (SCART)	0.7Vpp into 75 ohm
AUDIO FORMAT	Crosstalk (1kHz)
Digital	Mpeg/AAC-3/ DTS compressed Digital
	PCM
	MP3 (ISO 9660)
	fs 44.1, 48, 96 kHz
	96, 112, 128, 256
	kbps & variable
	bit rate fs, 32, 44.1,
	48 kHz
	100 dB
	Distortion/noise (1kHz)
	105 dB
	MPEG MP3
	MPEG Audio L3
CONNECTIONS	90 dB
Scart Output	Euroconnector
Video Output	Cinch (yellow)
Audio Output(L+R)	Cinch (black/white)
Digital Output	I-coaxial, 1 optical
	IEC958 for CDDA / LPCM
	IEC1937 for MPEG 1/2, Dolby
	Digital and DTS
CABINET	
Dimensions (w x d x h)	435 x 43 x 300 mm
Weight	Approximately 2.8 Kg
POWER CONSUMPTION	
Power consumption in Standby mode	<1W

Specifications subject to change without prior notice

## Troubleshooting

Problem	Solution
<b>No audio at digital output</b>	<ul style="list-style-type: none"> <li>Check the digital connections.</li> <li>Check if your receiver can decode MPEG-2 or DTS and if not, please make sure the digital output is set to PCM.</li> <li>Check if the audio format of the selected audio language matches your receiver capabilities.</li> </ul>
<b>No sound and picture</b>	<ul style="list-style-type: none"> <li>Check that the SCART cable is connected to the correct device. (See Connecting to a TV)</li> </ul>
<b>Disc can't be played</b>	<ul style="list-style-type: none"> <li>The DVD+R/DVD+RW/CD-R must be finalized.</li> <li>Ensure the disc label is facing up.</li> <li>Check if the disc is defective by trying another disc.</li> <li>If you have record a Picture CD or MP3 CD yourself, ensure that your disc contains at least 10 pictures or 5 MP3 tracks.</li> <li>Region code incorrect.</li> </ul>
<b>Picture freezes momentarily during playback</b>	<ul style="list-style-type: none"> <li>Check the disc for fingerprints/scratches and clean with a soft cloth wiping from centre to edge.</li> </ul>
<b>No return to start-up screen when disc is removed</b>	<ul style="list-style-type: none"> <li>Reset the unit by switching the Player off, then on again.</li> </ul>
<b>The Player does not respond to the remote control</b>	<ul style="list-style-type: none"> <li>Aim the remote control directly at the sensor on the front of the Player.</li> <li>Reduce the distance to the Player.</li> <li>Replace the batteries in the remote control.</li> <li>Insert the batteries with their polarities (+/- signs) as indicated.</li> </ul>
<b>Buttons do not work</b>	<ul style="list-style-type: none"> <li>In order to completely reset the Player, unplug the AC cord from the AC outlet.</li> </ul>
<b>Player does not respond to some operating commands during playback</b>	<ul style="list-style-type: none"> <li>Operations may not be permitted by the disc. Refer to the instructions of the disc.</li> </ul>
<b>DVD Video Player cannot read CDs/DVDs</b>	<ul style="list-style-type: none"> <li>Use a commonly available cleaning CD/DVD to clean the lens before sending the DVD Video Player for repair.</li> </ul>
<b>Menu items cannot be selected</b>	<ul style="list-style-type: none"> <li>Press STOP twice before selecting System Menu.</li> <li>Depending on the disc availability, some menu items cannot be selected.</li> </ul>

**if you are unable to remedy a problem by following these hints, consult your dealer or service centre (HOTLINE).**

## Maintenance

### Cleaning the Cabinet

- Use a soft cloth slightly moistened with a mild detergent solution. Do not use a solution containing alcohol, spirits, ammonia or abrasives.

### Cleaning Discs

- When a disc becomes dirty, clean it with a cleaning cloth. Wipe the disc from the center out. Do not wipe in a circular motion.
- Do not use solvents such as benzine, thinner, commercially available cleaners, or antistatic spray intended for analog records.

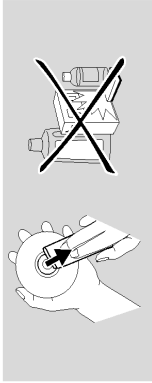

## Troubleshooting

### WARNING

**Under no circumstances should you try to repair the system yourself, as this will invalidate the warranty. Do not open the system as there is a risk of electric shock.**

**If a fault occurs, first check the points listed below before taking the system for repair. If you are unable to remedy a problem by following these hints, consult your dealer or service center.**

Problem	Solution
<b>No power</b>	<ul style="list-style-type: none"> <li>Check if the AC power cord is properly connected.</li> </ul>
<b>No picture</b>	<ul style="list-style-type: none"> <li>Check if the TV is switched on.</li> <li>Check the video connection.</li> </ul>
<b>Distorted picture</b>	<ul style="list-style-type: none"> <li>The disc is badly scratched or dirty.</li> <li>Sometimes a small amount of picture distortion may appear. This is not a malfunction.</li> </ul>
<b>Completely distorted picture or black/white picture with DVD or Video CD</b>	<ul style="list-style-type: none"> <li>Make sure the NTSC/PAL setting at the DVD Player matches the video signal of your television. (See NTSC/PAL CONVERSION)</li> <li>If the picture becomes distorted after switching between PAL and NTSC, please set the SMART PICTURE to STANDARD.</li> </ul>
<b>No sound or distorted sound</b>	<ul style="list-style-type: none"> <li>Adjust the volume.</li> <li>Check that the speakers are connected correctly.</li> </ul>



# 4. Mechanical- and Dismantling Instructions

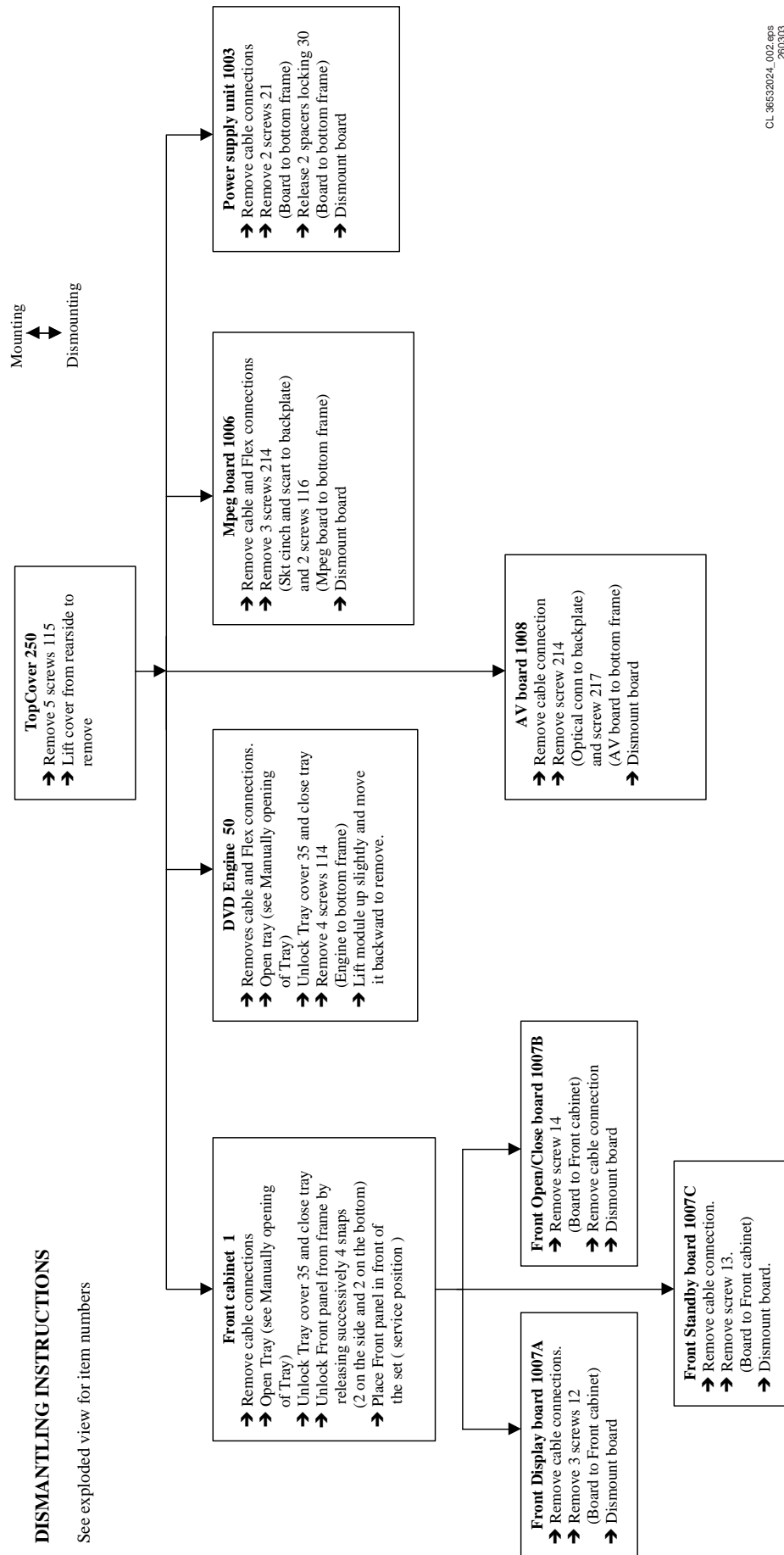
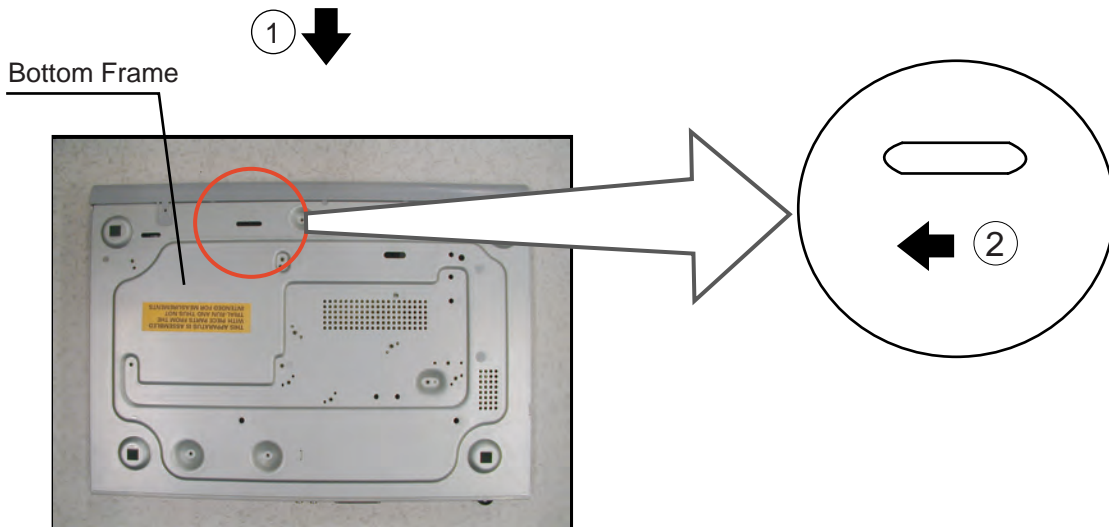
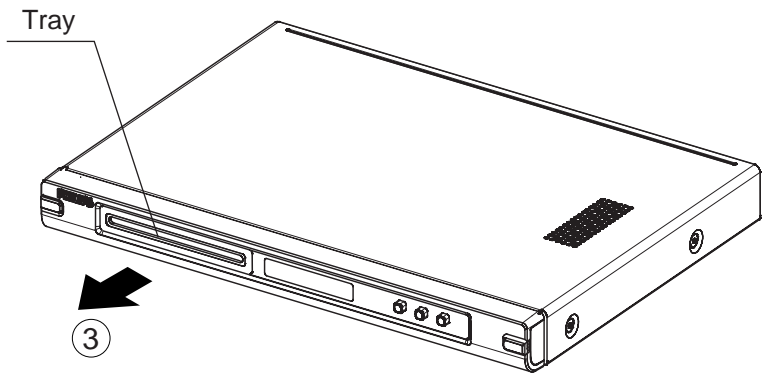

Figure 4-1 Dismantling Instructions

HOW TO MANUAL EJECT THE TRAY

- 1. Turn the player bottom up.
- 2. Move the slid to the LEFT direction with a screw driver until the tray is ejected.
- 3. Gently pull the tray out.



CL 36532024\_003.eps  
240303

Figure 4-2 Manually opening of tray

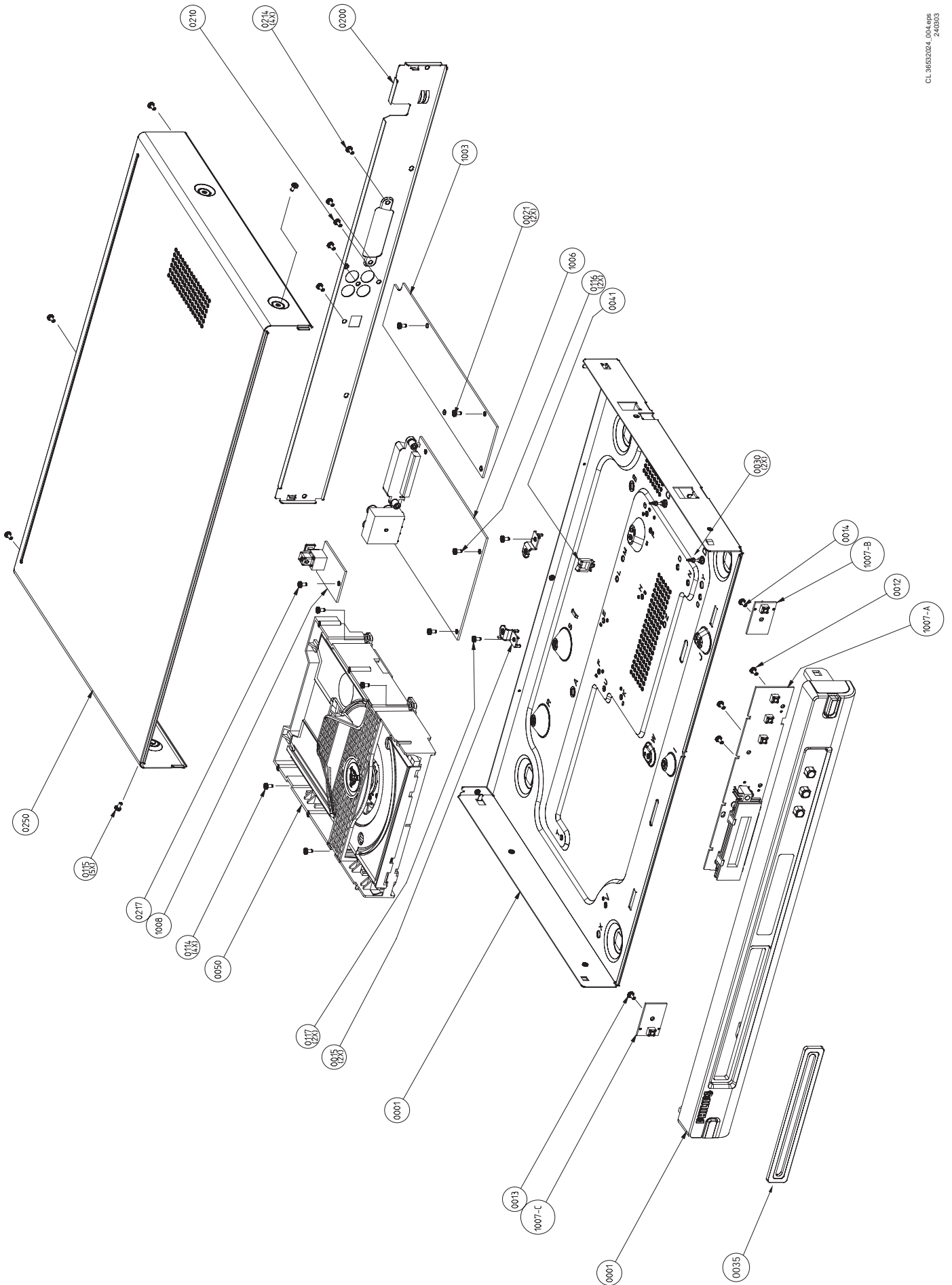

Figure 4-3 Exploded View

## 5. Service Hints, Trouble Shooting and Fault Finding

### 5.1 Service Hints

#### 5.1.1 Repair tips

##### **Switched mode power supply**

The power supply unit has to be replaced in case of failure. The schematic diagram provided in the service manual is only for information and no service parts will be available.

##### **DVD Loader**

The DVD Loader is a non-repairable unit and in case of failure, it has to be replaced with a complete DVD Loader.

##### **Mpeg board and Front Display**

The Mpeg board and Front display has to be repaired down to component level.

#### 5.1.2 Change of Software setting

The software setting can be change according to the following procedure:

1. Press "OPEN/CLOSE" button on the front of the player to open the disc tray.
2. Enter the 4-digit code <9> <9> <9> <9> on the remote control.
3. Enter one of the keys below to change the software setting.

<b>REGION CODE</b>	USA	==> 1
	EUROPE	==> 2
	AP	==> 3
	LATAM	==> 4
	INDIA / RUSSIA	==> 5
	CHINA	==> 6

< **AUDIO** > < **7** >: Set to setup configuration of DVD728 / 729 / 731 European models

The change should effect immediately with information indicated on TV screen.

**Note:** When changing the setup configuration, the change will take immediate effect with the information indicated on the TV screen for a short period and the tray will close automatically and player will go to standby.

#### 5.1.3 Software upgrade via Download disc

Both the application and servo software are delivered in one sw stack and it can be flashed into the DVD player by means of a CD-ROM disc. The CD-ROM disc has to be made with a CD writer SW.

##### **Note:**

1. The file name used for writing on the CD-R/RW MUST be in UPPER-CASE.eg: SD542AP.BIN
2. For better and fast reading, add one big garbage file of 50-100MB.

##### **Software upgrade procedure**

1. Open disc tray on the player.
2. Insert the DOWNLOAD DISC into the player and close disc tray.
3. The upgrading operation will start automatically.
4. The VFD will display the upgrading progress, 'ERASE...'->'WRITE F'-->...-->'WRITE 0'--> UPGRADE end or the LED will turn ON and OFF)
5. The upgrading will take approximately about 1 minute.
6. Once when the software is upgraded, the disc tray will automatically eject.

7. The player will be restarted automatically and display on VFD will show < NO DISC >.

##### **Important note:**

Do not power off or interrupt the mains during the upgrading else the player's flash memory will be erased.

#### 5.1.4 Verify setting

To check that the setting has change successfully.

1. Press "DISPLAY" button on the remote control while disc tray is open.
2. Two lines text will appear on the TV screen. That is how it looks like.

**SD542PH-030219-728-001N**  
**SERVO:001FC72 REG:2**

In text, the following numbers refer to:

<b>SD542PH-030219</b>	==> refer to Application software version
<b>REG 2</b>	==>refer to region code
<b>SERVO:001FC72</b>	==> refer to servo software version
<b>728-001N</b>	==> refer to setup configuration of a type number, eg. DVD728/001

#### 5.1.5 ComPair

There is no ComPair available

### 5.2 Trouble Shooting

In this paragraph some troubleshooting tips are given to diagnose the DVD player. For detailed diagnostics, check the faulting tree since no built-in diagnostic software is available in the player.

#### 5.2.1 Test Disc

The following test discs are recommended for use to test the playability of the player:

1. DVD disc: MPTD CVP 02.18 -  
12nc: 7104 099 91691
2. Audio disc (CDDA): Subchassis 8a test disc -  
12nc: 7104 099 28362

5.3 Fault Finding Trees System Working Procedure for MediaTek DVD-Player (MT1379 + MT1366)

5.3.1 No Operation

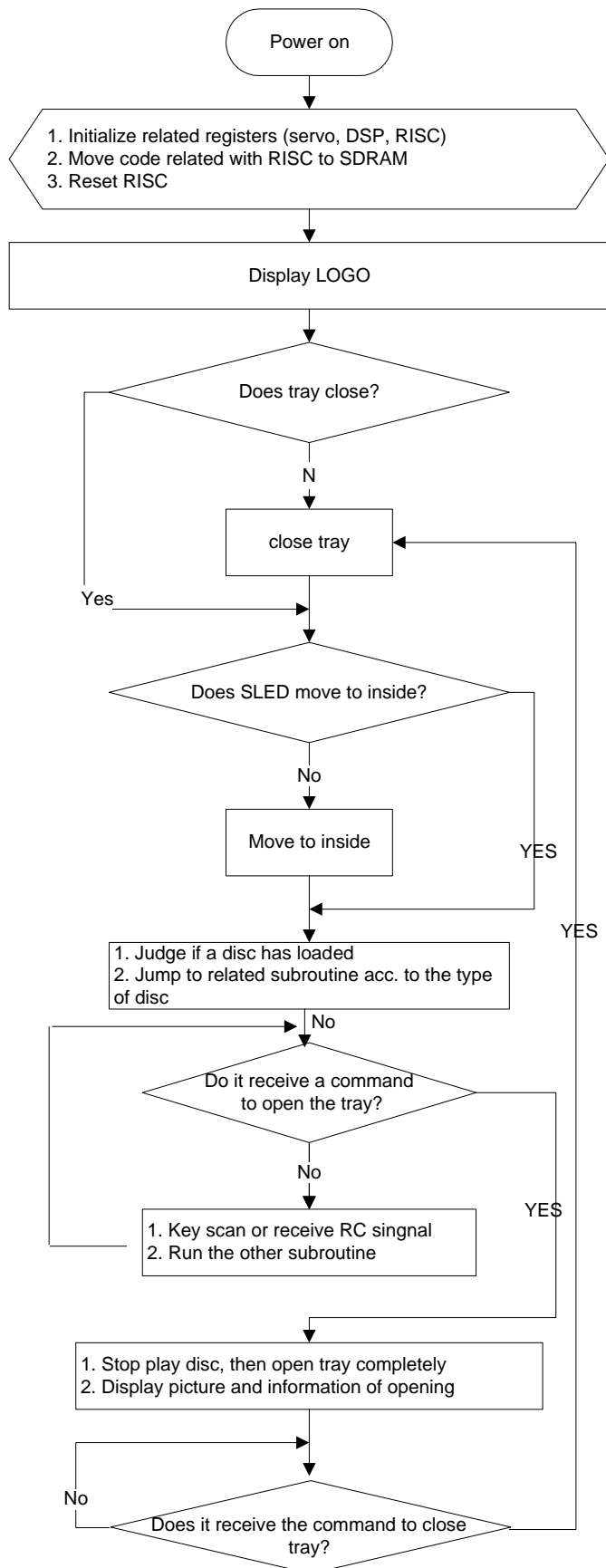

CL 36532024\_005.eps

Figure 5-1 No Operation

5.3.2 No Picture

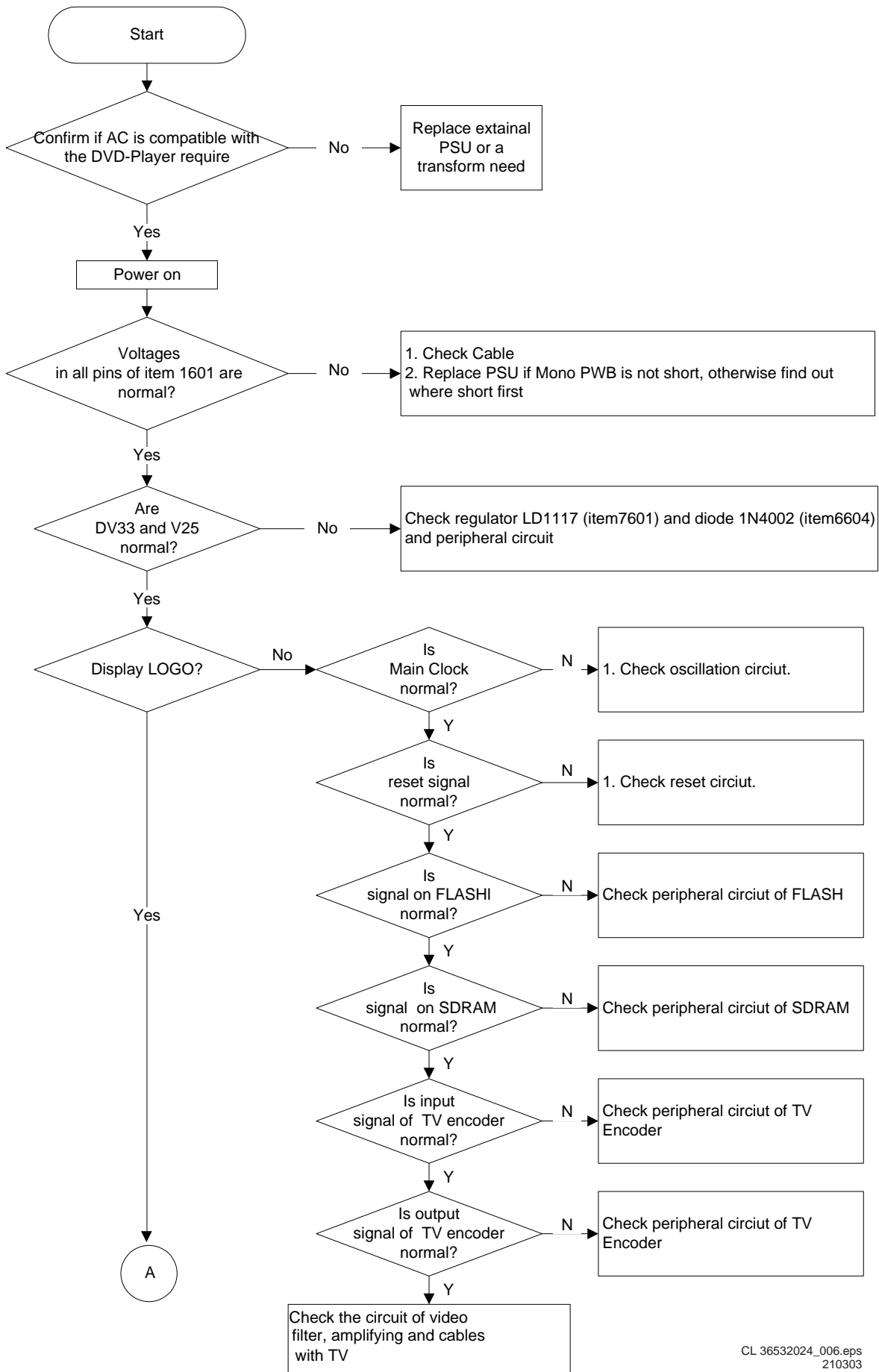
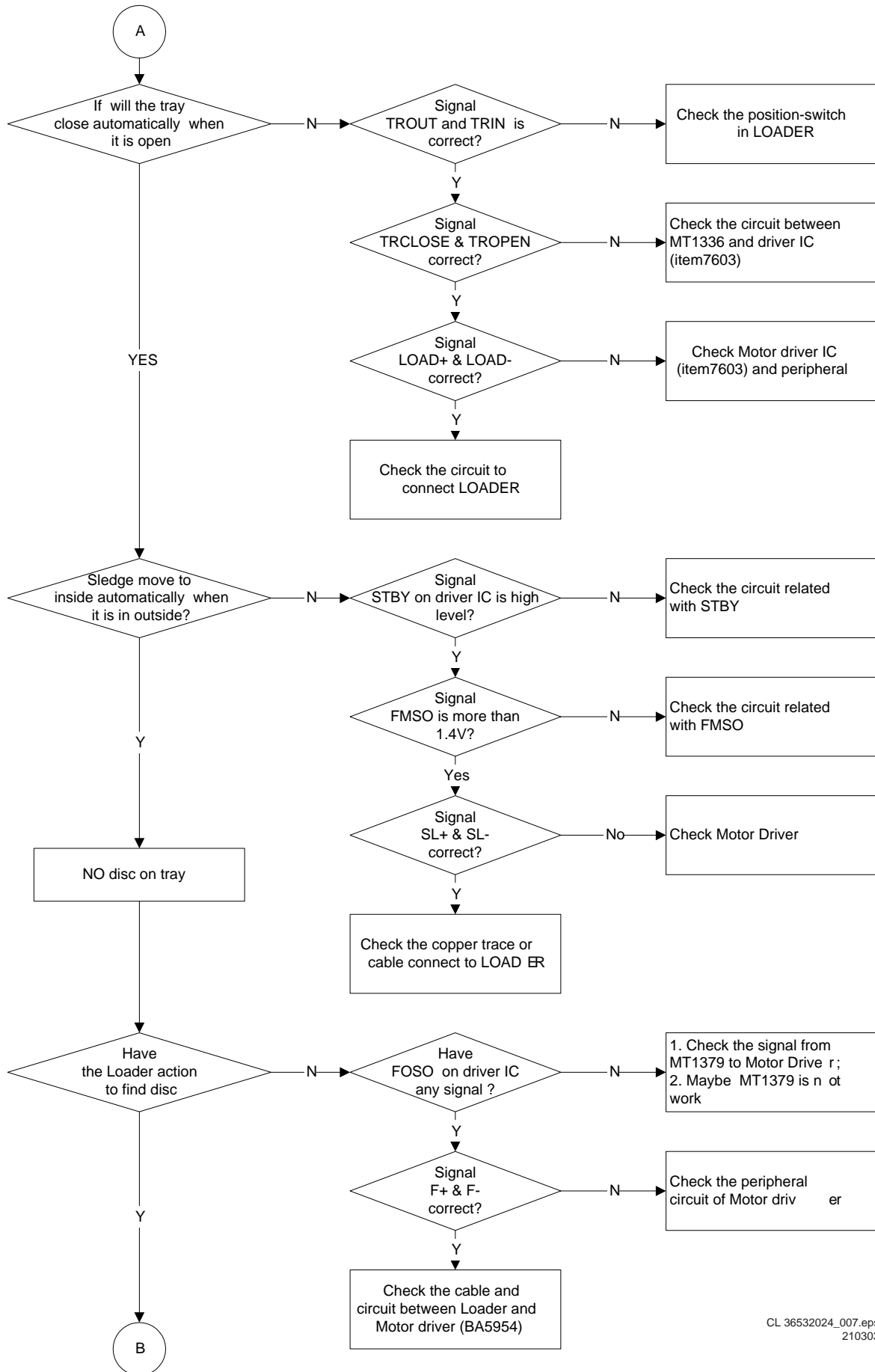

Figure 5-2 No Picture

5.3.3 No Color



CL 36532024\_007.eps  
210303

Figure 5-3 Pix no color

5.3.4 No Sound

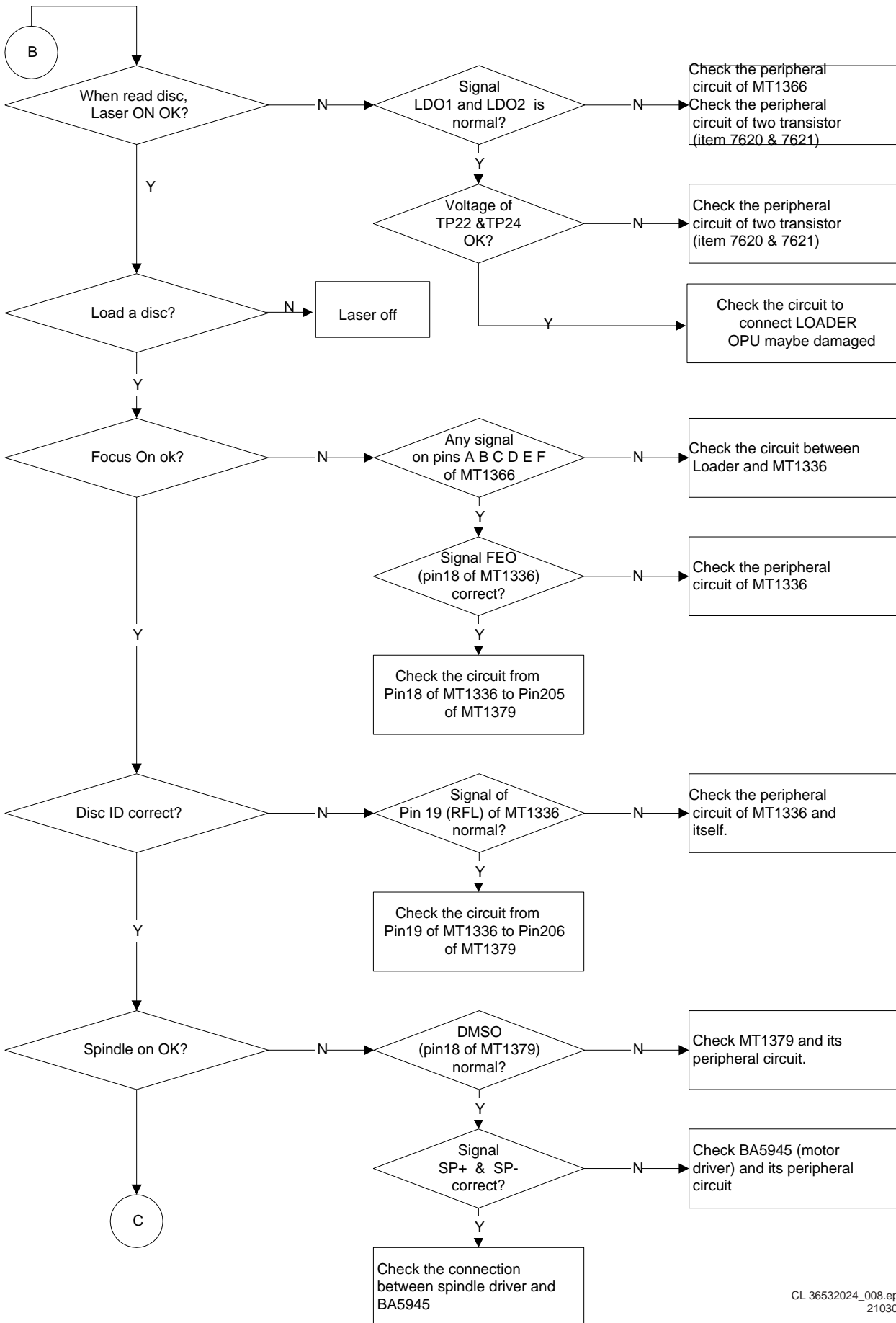

Figure 5-4 No Sound



5.3.5 No Digital Audio Out

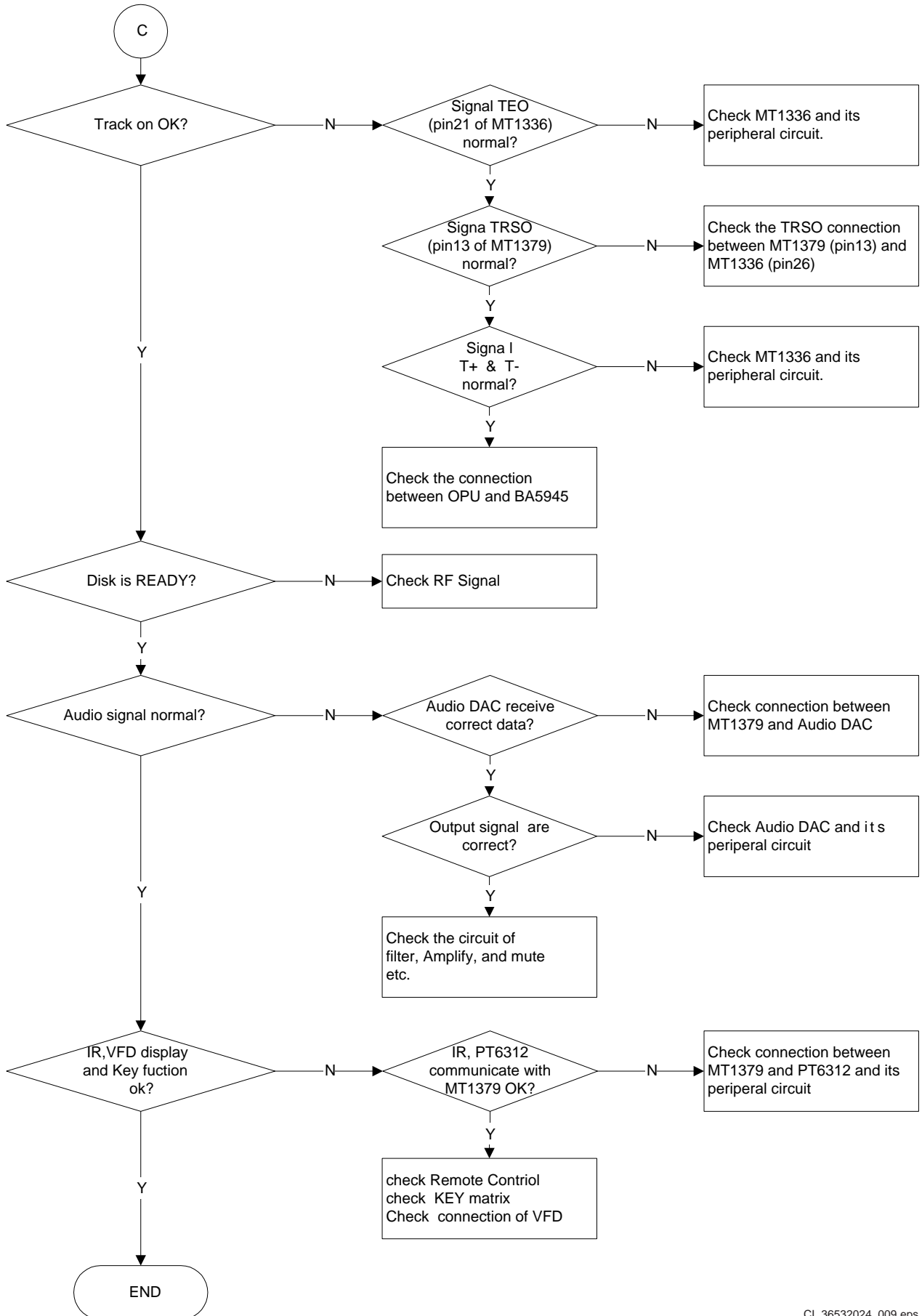

Figure 5-5 No Digital audio out



## 6. Block and Wiring Diagram.

### Block Diagram

BLOCK DIAGRAM DVD728 / DVD729 /DVD731

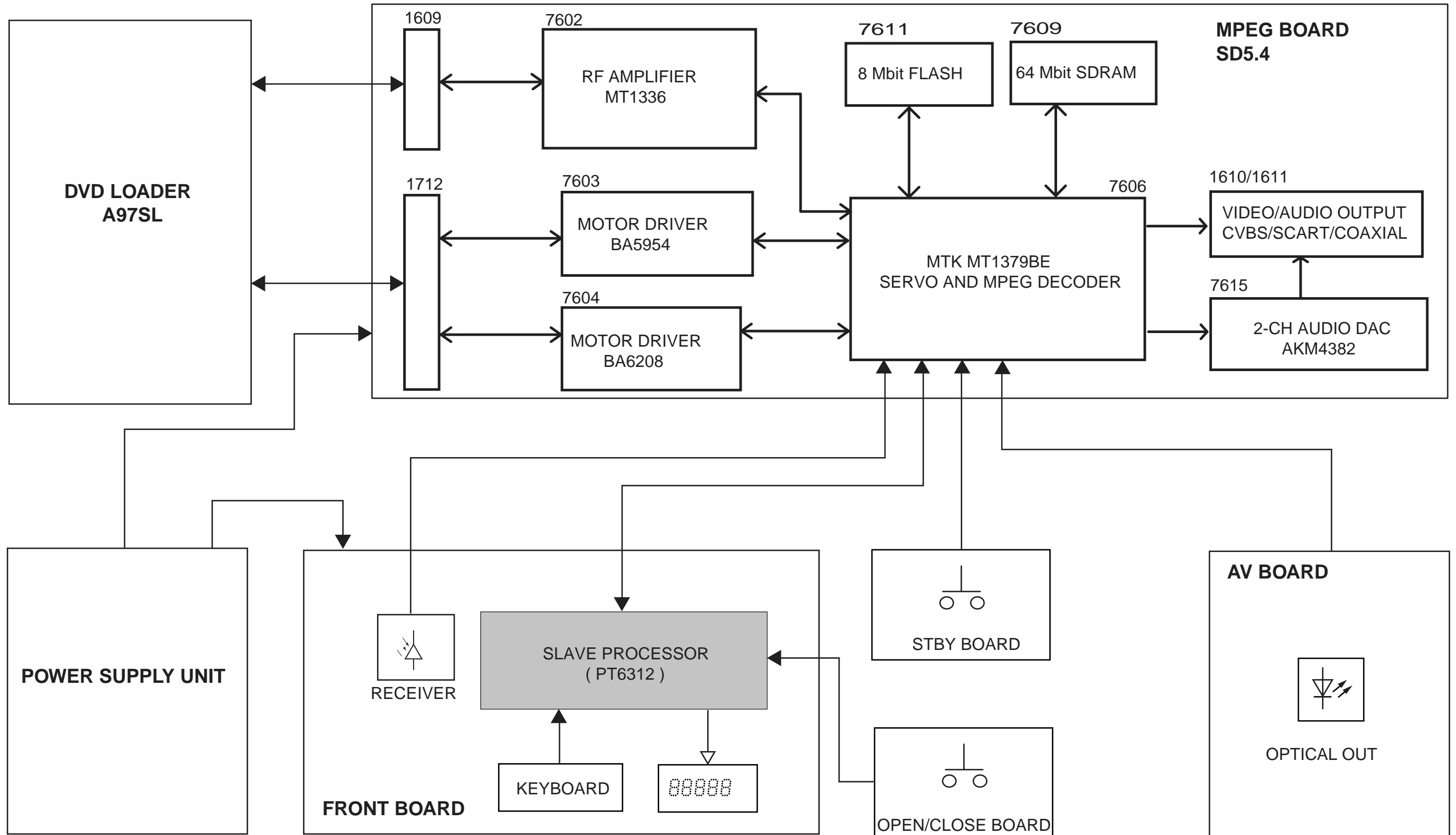

Wiring Diagram

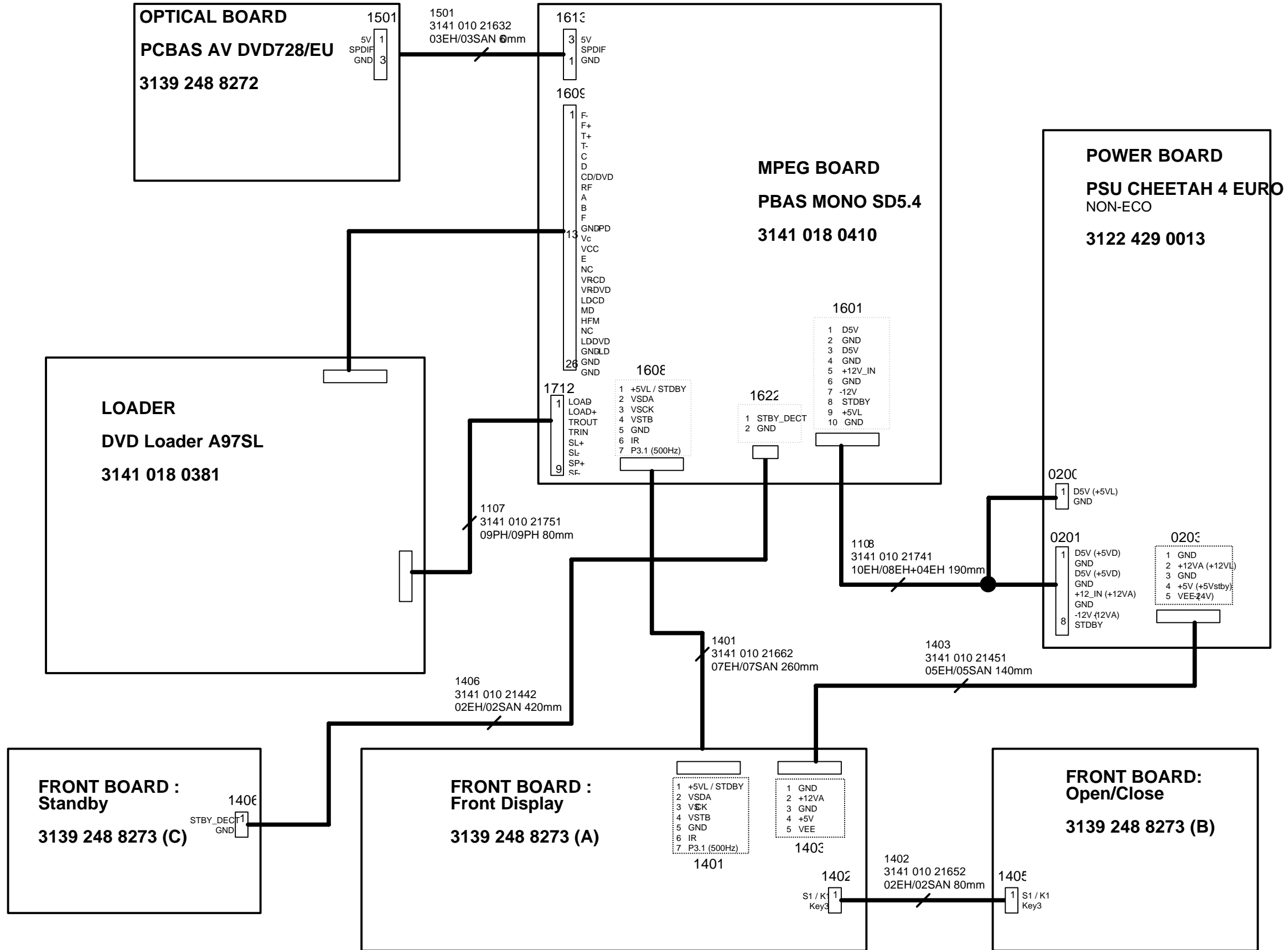

Test Point Overview MPEG Board

SD5.42 MPEG PCB Layout - Bottom view

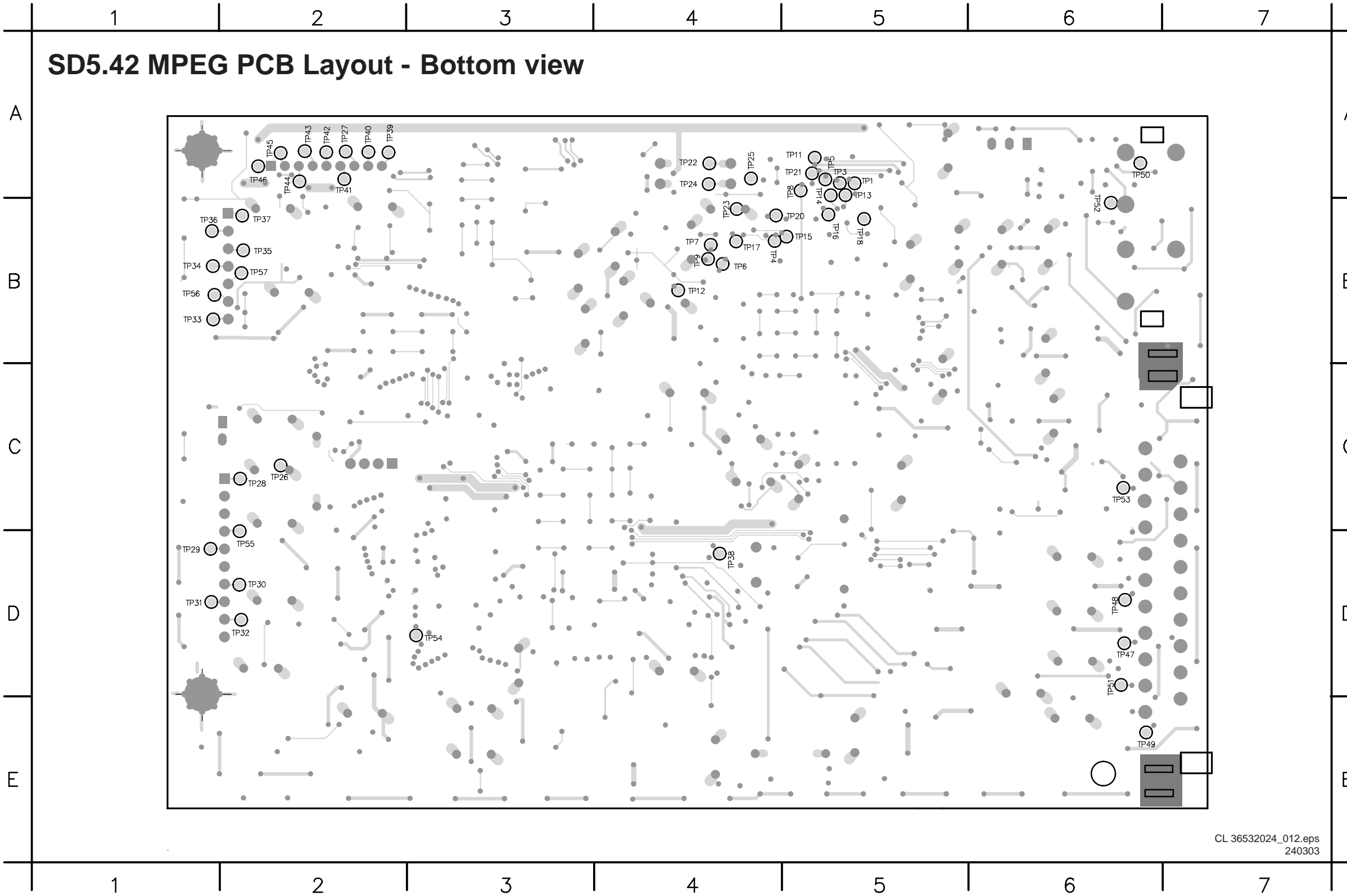

TP1	A5	TP47	D6
TP3	A5	TP48	D6
TP4	B4	TP49	E6
TP5	A5	TP50	A6
TP6	B4	TP51	D6
TP7	B4	TP52	B6
TP8	A5	TP53	C6
TP9	B4	TP54	D3
TP11	A5	TP55	D2
TP12	B4	TP56	B1
TP13	A5	TP57	B2
TP14	A5		
TP15	B5		
TP16	B5		
TP17	B4		
TP18	B5		
TP20	B4		
TP21	A5		
TP22	A4		
TP23	B4		
TP24	A4		
TP25	A4		
TP26	C2		
TP27	A2		
TP28	C2		
TP29	D1		
TP30	D2		
TP31	D1		
TP32	D2		
TP33	B1		
TP34	B1		
TP35	B2		
TP36	B1		
TP37	B2		
TP38	D4		
TP39	A2		
TP40	A2		
TP41	A2		
TP42	A2		
TP43	A2		
TP44	A2		
TP45	A2		
TP46	A2		

# 7. Electrical Diagrams

## Power Supply Unit

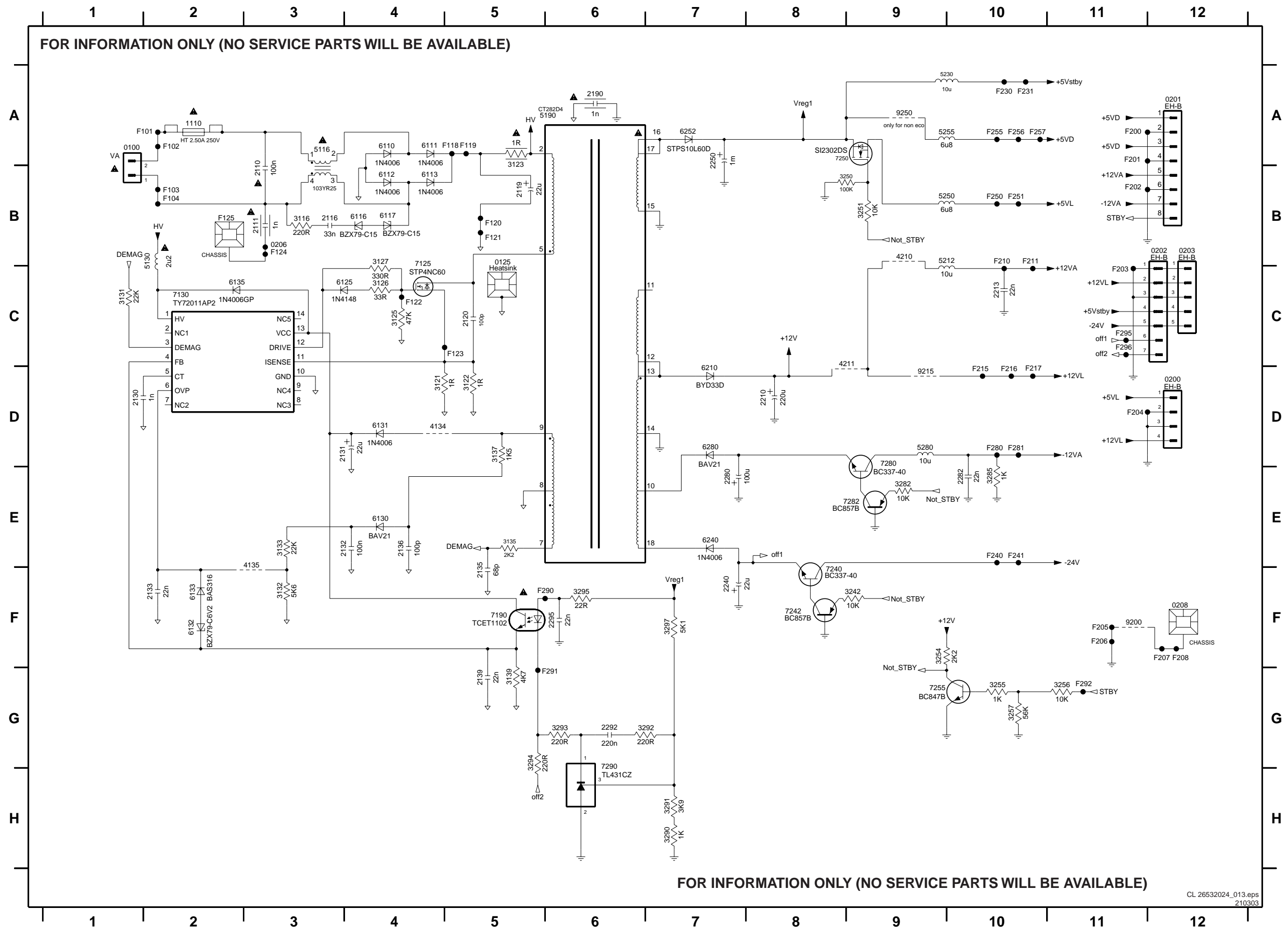

0100 A1	5255 A10
0125 B5	5280 D9
0200 D12	6110 A4
0201 A12	6111 A4
0202 B12	6112 B4
0203 B12	6113 B4
0206 B3	6116 B4
0208 F12	6117 B4
1110 A2	6125 C4
2110 B3	6126 D2
2111 B3	6130 E4
2116 B3	6131 D4
2117 B5	6132 F2
2118 B5	6133 F2
2119 B5	6134 F3
2120 C5	6135 C2
2129 E3	6210 D7
2130 D1	6240 E7
2131 D4	6250 B8
2132 E4	6251 B8
2133 F2	6252 A7
2135 E5	6271 C7
2136 E4	6280 D7
2139 G5	7125 C4
2190 A6	7130 C2
2200 F11	7190 F5
2210 D8	7210 C9
2212 C10	7211 D9
2213 C10	7212 C9
2215 D10	7240 F8
2216 D10	7242 F8
2230 A10	7250 A8
2240 F7	7255 G9
2250 A7	7256 F9
2252 B10	7280 D9
2253 B10	7282 E8
2254 F10	7290 H6
2255 A10	9200 F11
2256 A10	9215 D9
2271 C7	9250 A9
2280 E7	F101 A2
2282 E10	F102 A2
2291 G6	F103 B2
2292 G6	F104 B2
2295 F6	F118 A5
3110 B2	F119 A5
3116 B3	F120 B5
3120 D4	F121 B5
3121 D4	F122 C4
3122 D5	F123 C5
3123 A5	F124 B3
3125 C4	F125 B2
3126 C4	F200 A11
3127 B4	F201 A11
3128 D2	F202 B11
3129 E2	F203 C11
3131 C1	F204 D11
3132 F3	F205 F11
3133 E3	F206 F11
3135 E5	F207 F12
3136 D5	F208 F12
3137 D5	F210 B10
3139 G5	F211 B10
3210 C9	F215 D10
3212 C9	F216 D10
3213 C10	F217 D10
3215 C8	F230 A10
3216 D8	F231 A10
3240 F8	F240 E10
3242 F9	F241 E10
3250 B9	F250 B10
3251 B9	F251 B10
3253 B10	F255 A10
3254 F9	F256 A10
3255 G10	F257 A10
3256 G11	F280 D10
3257 G10	F281 D10
3258 A10	F290 F6
3259 F10	F291 G6
3271 C7	F292 G11
3282 E9	F295 C11
3285 E10	F296 C11
3290 H7	
3291 H7	
3292 G7	
3293 G6	
3294 G5	
3295 F6	
3296 G6	
3297 F7	
3298 F6	
4134 D4	
4135 F3	
4210 B9	
4211 D9	
4250 A9	
5115 A3	
5116 A3	
5130 B2	
5190 A5	
5212 B10	
5215 D9	
5230 A10	
5250 B10	

Front Display Board

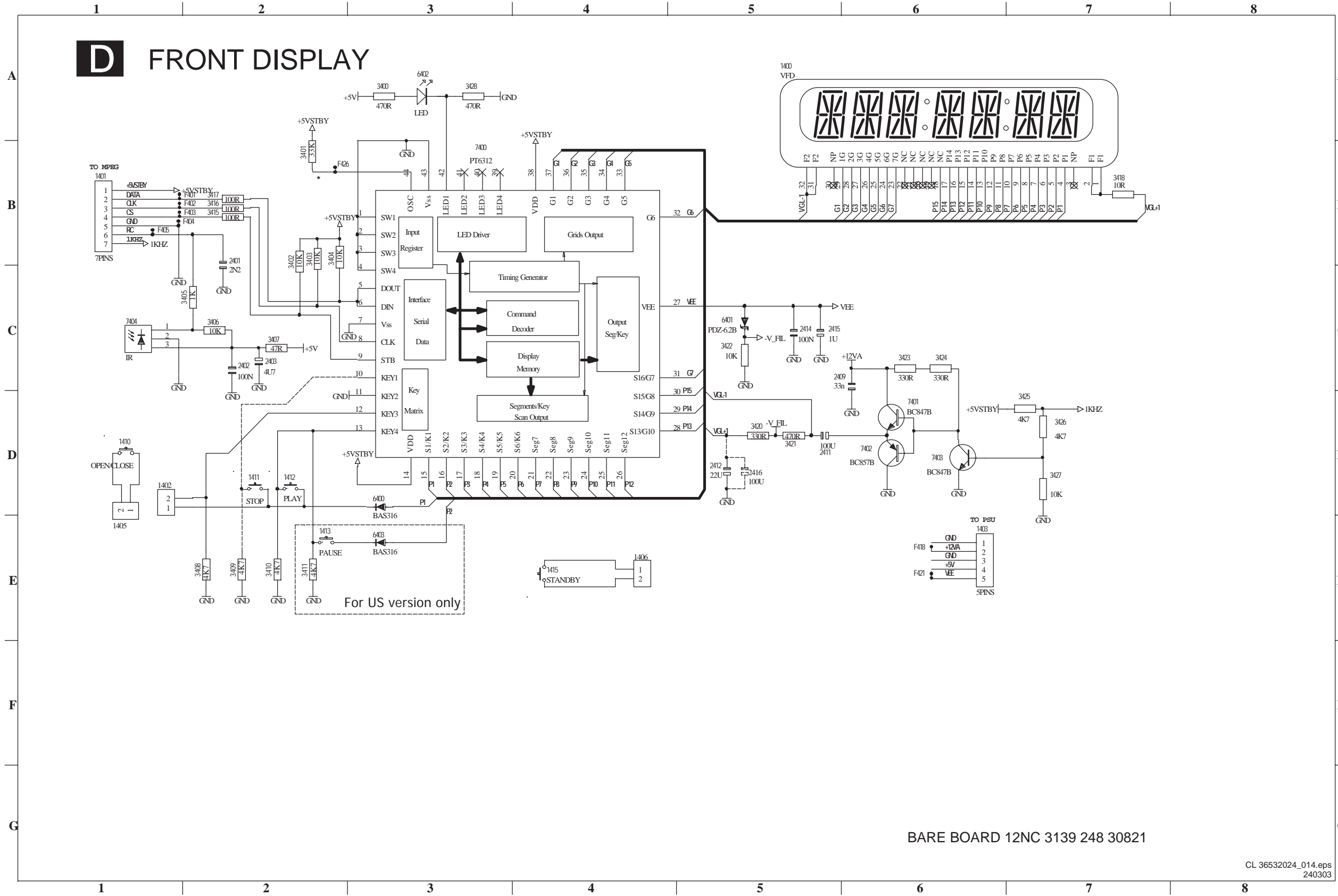

- 1400 B5
- 1401 B1
- 1402 D2
- 1403 E7
- 1405 D1
- 1406 E4
- 1410 D1
- 1411 D2
- 1412 D2
- 1413 E2
- 1415 E4
- 2401 B2
- 2402 C2
- 2403 C2
- 2409 C6
- 2411 D6
- 2412 D5
- 2414 C5
- 2415 C6
- 2416 D5
- 3400 A3
- 3401 A2
- 3402 A2
- 3403 B3
- 3404 B3
- 3405 C2
- 3406 C2
- 3407 C2
- 3409 E2
- 3410 E2
- 3411 E2
- 3415 B2
- 3416 B2
- 3417 B2
- 3418 B8
- 3420 D5
- 3421 D5
- 3422 C5
- 3423 C6
- 3424 C6
- 3425 D7
- 3426 D7
- 3427 D7
- 3428 A3
- 6400 D4
- 6401 C5
- 6402 A3
- 7400 B3
- 7401 D6
- 7402 D6
- 7403 D6
- 7404 C1

**Layout Display Board (Top Side)**

1400 B1 1403 A5 1410 A6 1413 B4 2411 B6 2416 A1 7404 A3 9402 B1 9405 B1 9408 B1 9411 B2 9414 B2 9417 B2 9420 B3 9423 A5 9427 B3  
 1401 A5 1405 B6 1411 B5 1415 A7 2412 A1 6401 B6 9400 B1 9403 B1 9406 B1 9409 B2 9412 B2 9415 A2 9418 A3 9421 B5 9424 A5  
 1402 A6 1406 B6 1412 B5 2403 A3 2415 A2 6402 B3 9401 B1 9404 B1 9407 B1 9410 B2 9413 B2 9416 B2 9419 B3 9422 B3 9425 A5

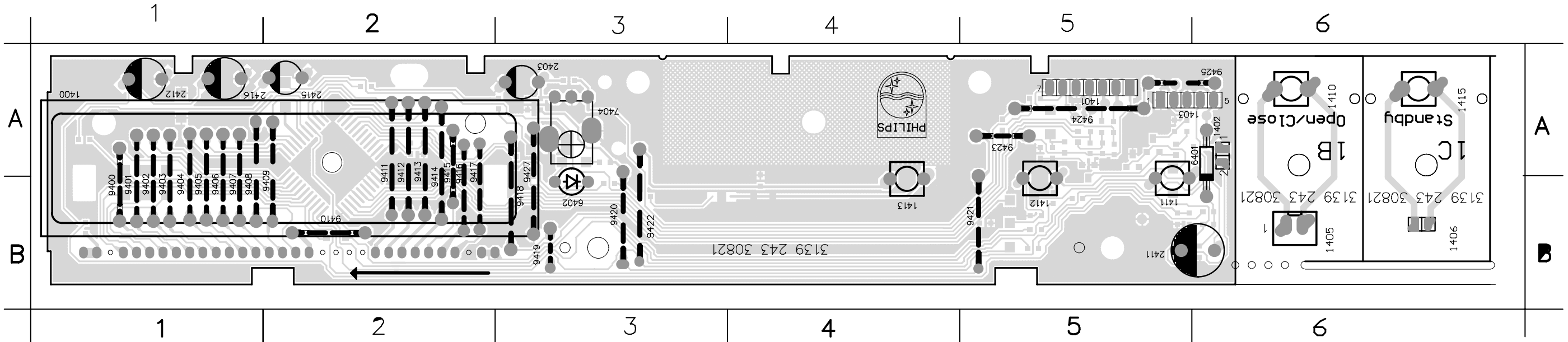

CL 36532024\_015.eps  
240303

**Layout Display Board (Bottom Side)**

2401 A5 3401 A2 3406 A3 3411 B4 3420 B6 3425 A5 3442 B1 3447 A1 3452 A3 3458 B5 3464 A5 6403 B4 F401 A5 F418 A5  
 2402 A3 3402 A5 3407 A3 3415 A5 3421 B6 3426 A5 3443 B1 3448 A3 3453 B3 3460 B5 3465 B5 7400 A2 F402 A5 F421 A6  
 2409 A5 3403 A5 3408 B5 3416 A5 3422 B6 3427 A5 3444 B1 3449 A3 3454 B3 3461 B5 3466 A6 7401 A5 F403 A5 F426 A2  
 2414 A1 3404 A5 3409 B5 3417 A5 3423 A5 3428 A2 3445 A2 3450 A3 3455 B5 3462 A5 3467 B5 7402 A5 F404 B5  
 3400 A3 3405 A5 3410 B5 3418 B1 3424 A5 3441 A1 3446 A2 3451 B5 3457 B5 3463 A5 6400 B2 7403 A5 F405 A5

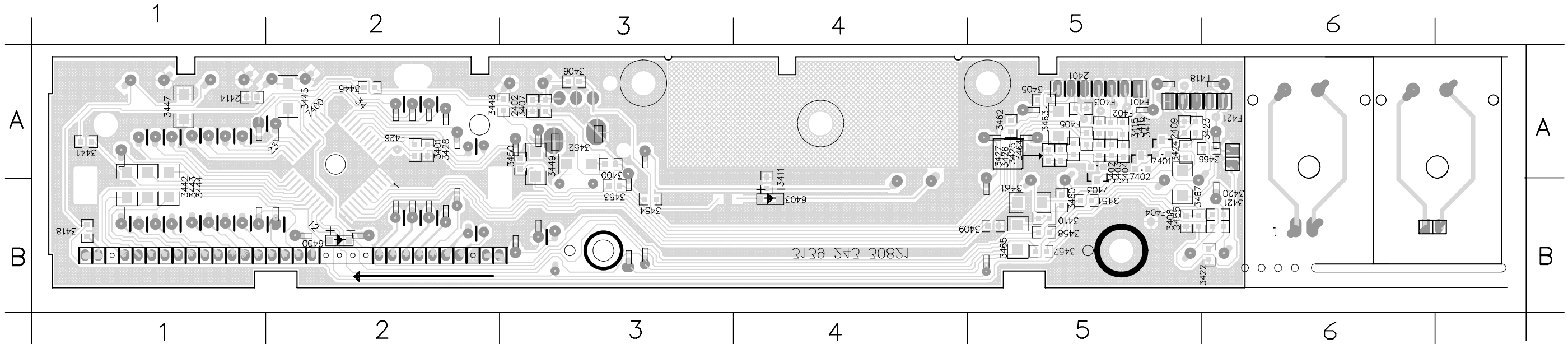

CL 36532024\_016.eps  
210303



AV Board

1501 A1 2501 A1 2502 A1 3501 A1 7501 A1

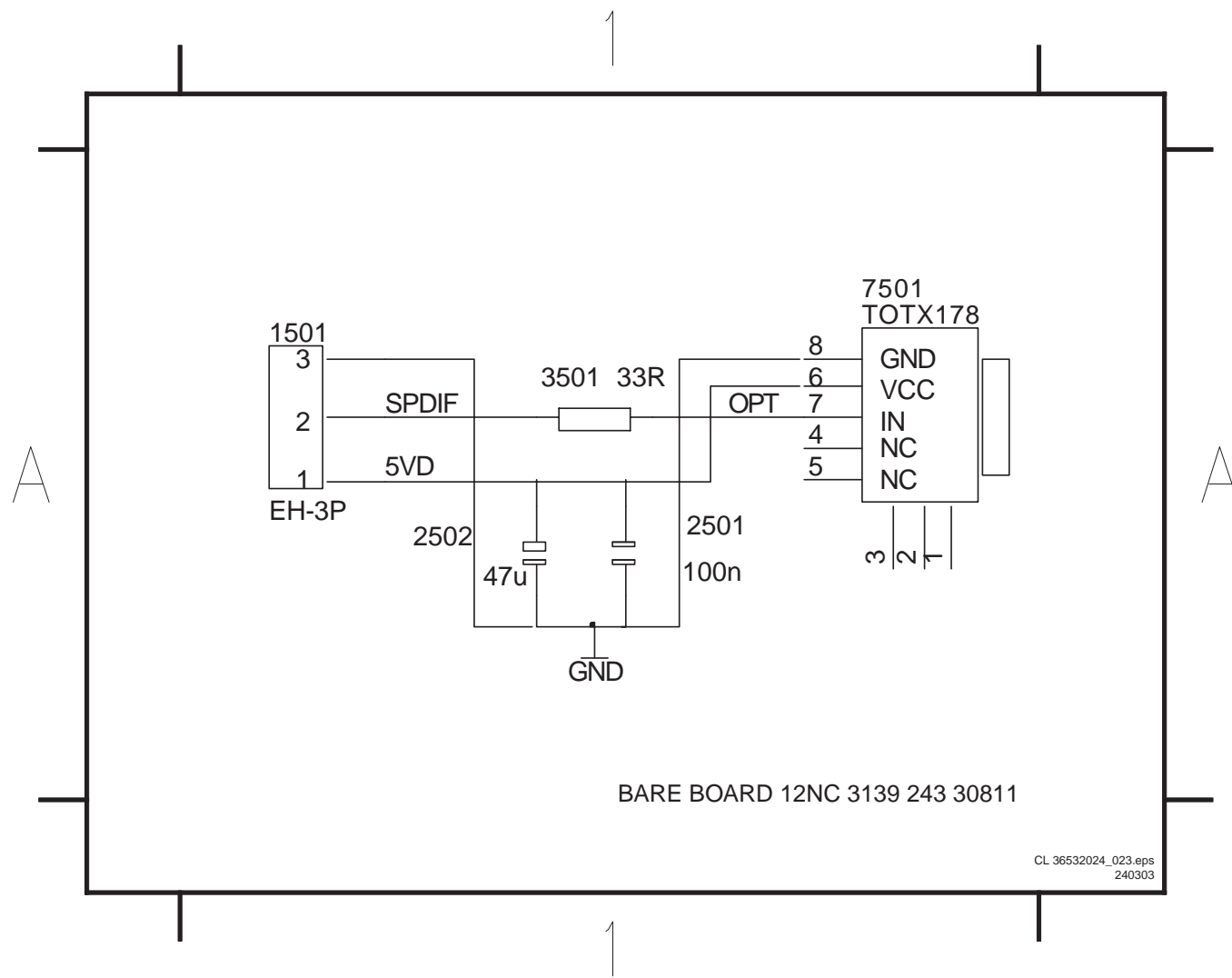

Layout AV Board (Top Side)

1501 A1 2502 A1 7501 A1

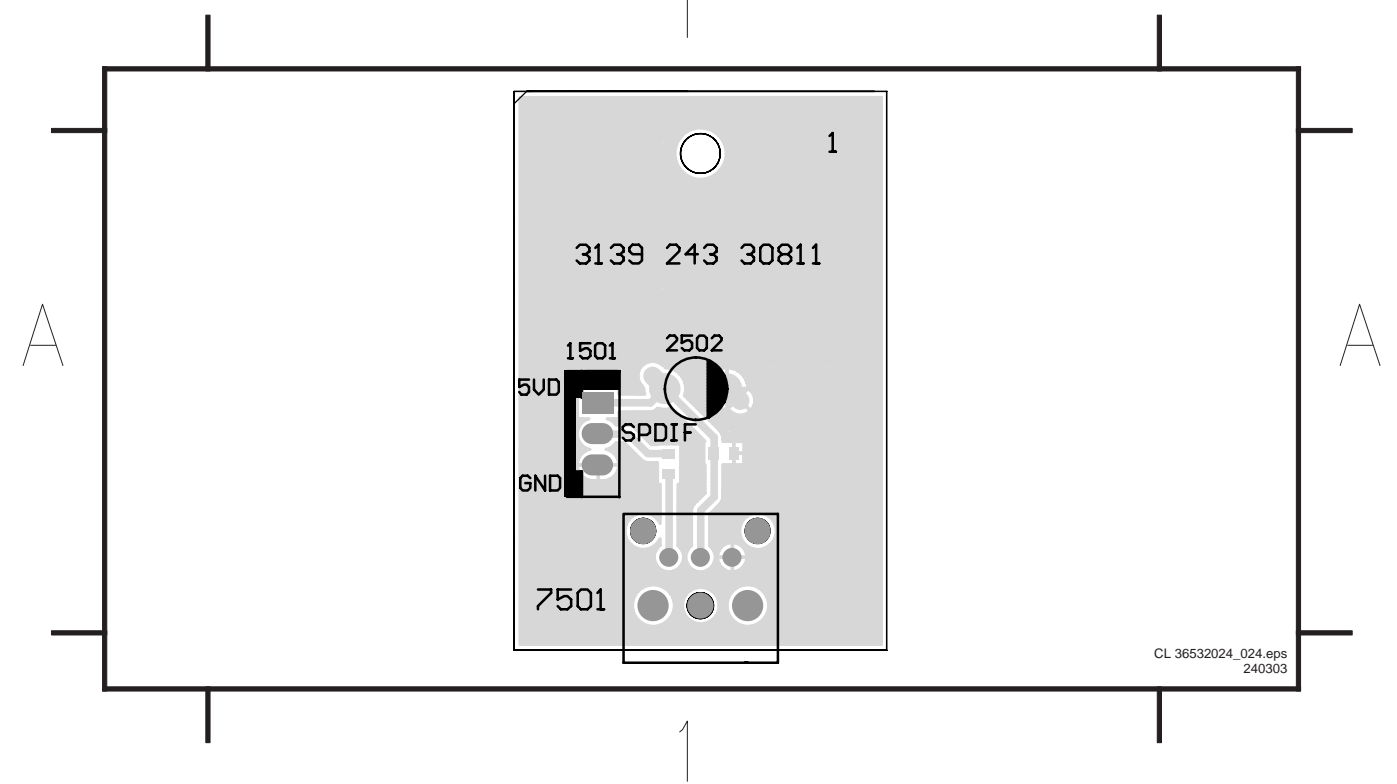

Layout AV Board (Bottom Side)

2501 A1 3501 A1

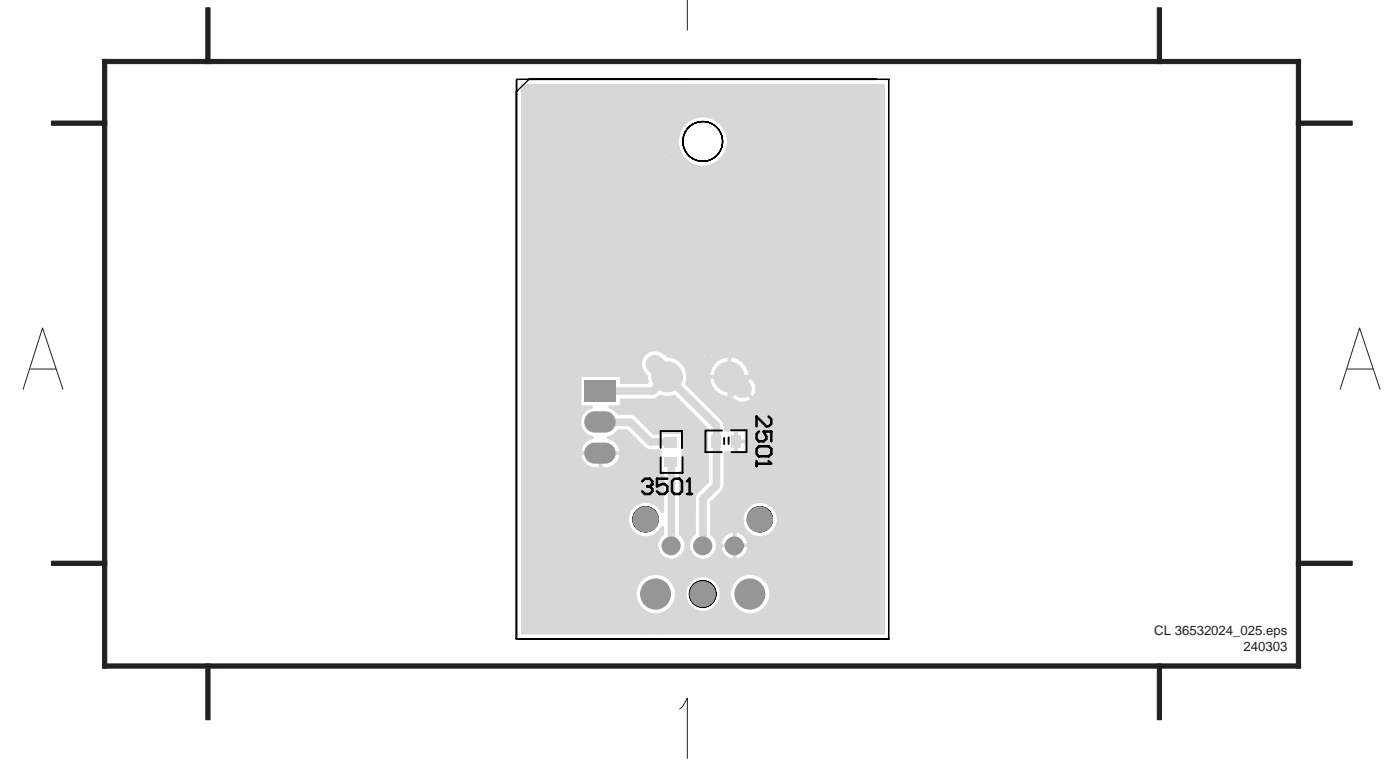

SD5.4 MPEG Board: Index

**M1** INDEX

NAME	TYPE	DEVICE
5VL	Digital 5V	SUPPLY
RVCC	Servo 5V	MT1336E
AVCC	RF 5V	PICKUP HEADER
DV33	Digital 3.3V	Flash, VideoDAC
DV33	Digital 3.3V	MT1369E
AV33	Servo 3.3V	MT1369E
V25	Digital 2.5V	MT1369E
SD33	Digital 3.3V	SDRAM
+5VV	VIDEO 5V	VIDEO
VCC5330	Audio 5V	Audio
+12V	Audio 12V	Audio filter
+5V8756D	Audio 5V	Audio DAC
+5V8756A	Audio 5V	Audio DAC

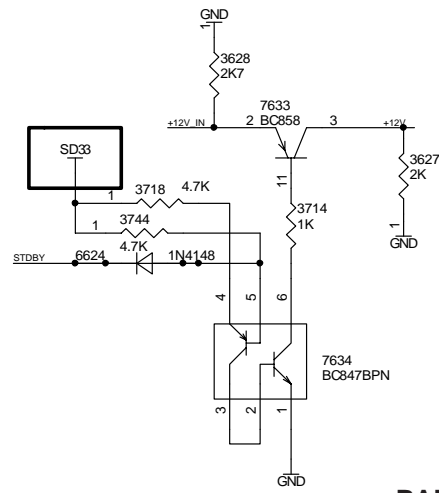
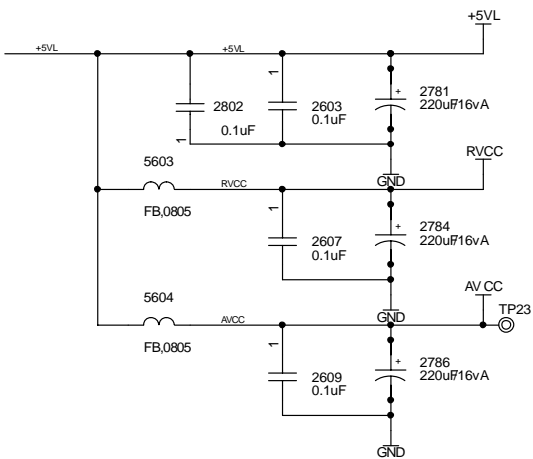
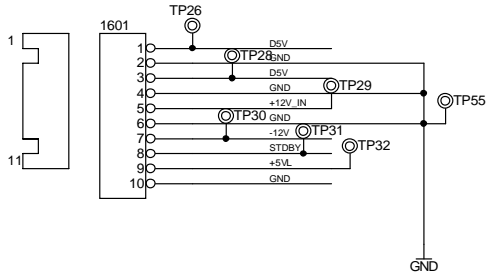

BARE BOARD 12NC 3141 013 31662

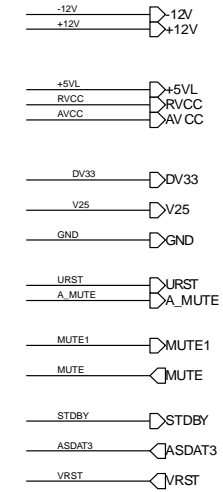
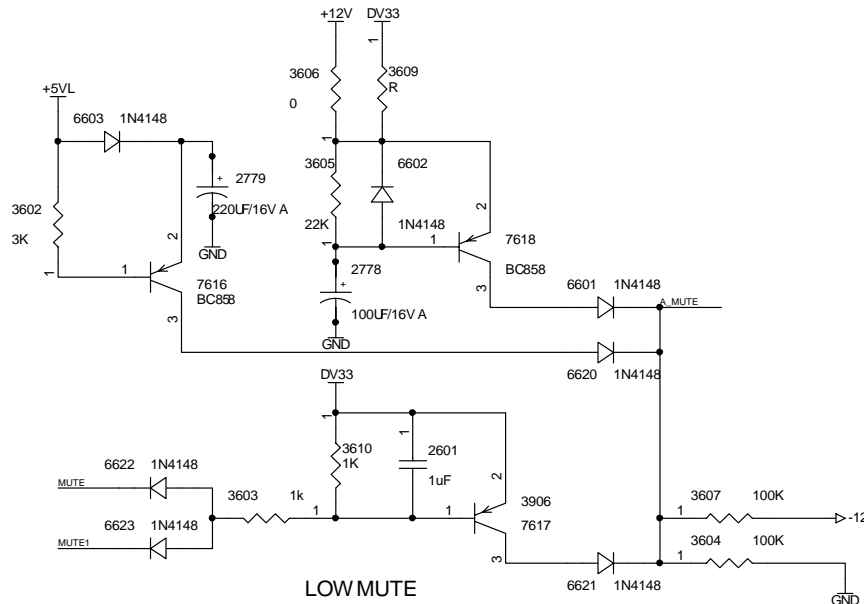
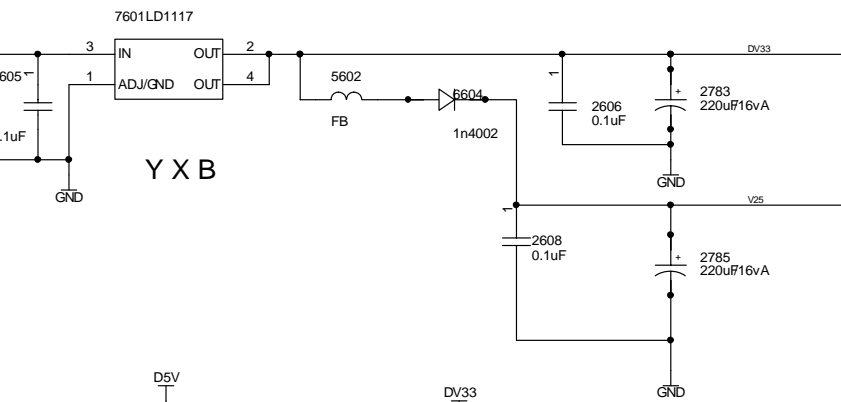

- 1601 C2
- 2601 C5
- 2603 D2
- 2605 C4
- 2606 C6
- 2607 E2
- 2608 D6
- 2609 E2
- 2706 D5
- 2778 B5
- 2779 B5
- 2781 D2
- 2782 D5
- 2783 C6
- 2784 E2
- 2785 D6
- 2786 E2
- 2800 C4
- 2802 D2
- 3602 B4
- 3603 C5
- 3604 C6
- 3605 B5
- 3606 B5
- 3607 C6
- 3609 B5
- 3610 C5
- 3611 E6
- 3627 D4
- 3628 D3
- 3714 D4
- 3718 D4
- 3744 E3
- 3747 D5
- 3748 E5
- 3749 D5
- 3832 D5
- 5602 C5
- 5603 E2
- 5604 E2
- 6601 B6
- 6602 B5
- 6603 B4
- 6604 C5
- 6605 E5
- 6620 B6
- 6621 C6
- 6622 C5
- 6623 C5
- 6624 E4
- 7601 C5
- 7616 B5
- 7617 C5
- 7618 B5
- 7633 D4
- 7634 E4
- 7635 D5
- 7636 E5
- TP23 E3
- TP26 C2
- TP28 C2
- TP29 C2
- TP30 C2
- TP31 C2
- TP32 C2
- TP55 C3

SD5.4 MPEG Board: RF Part

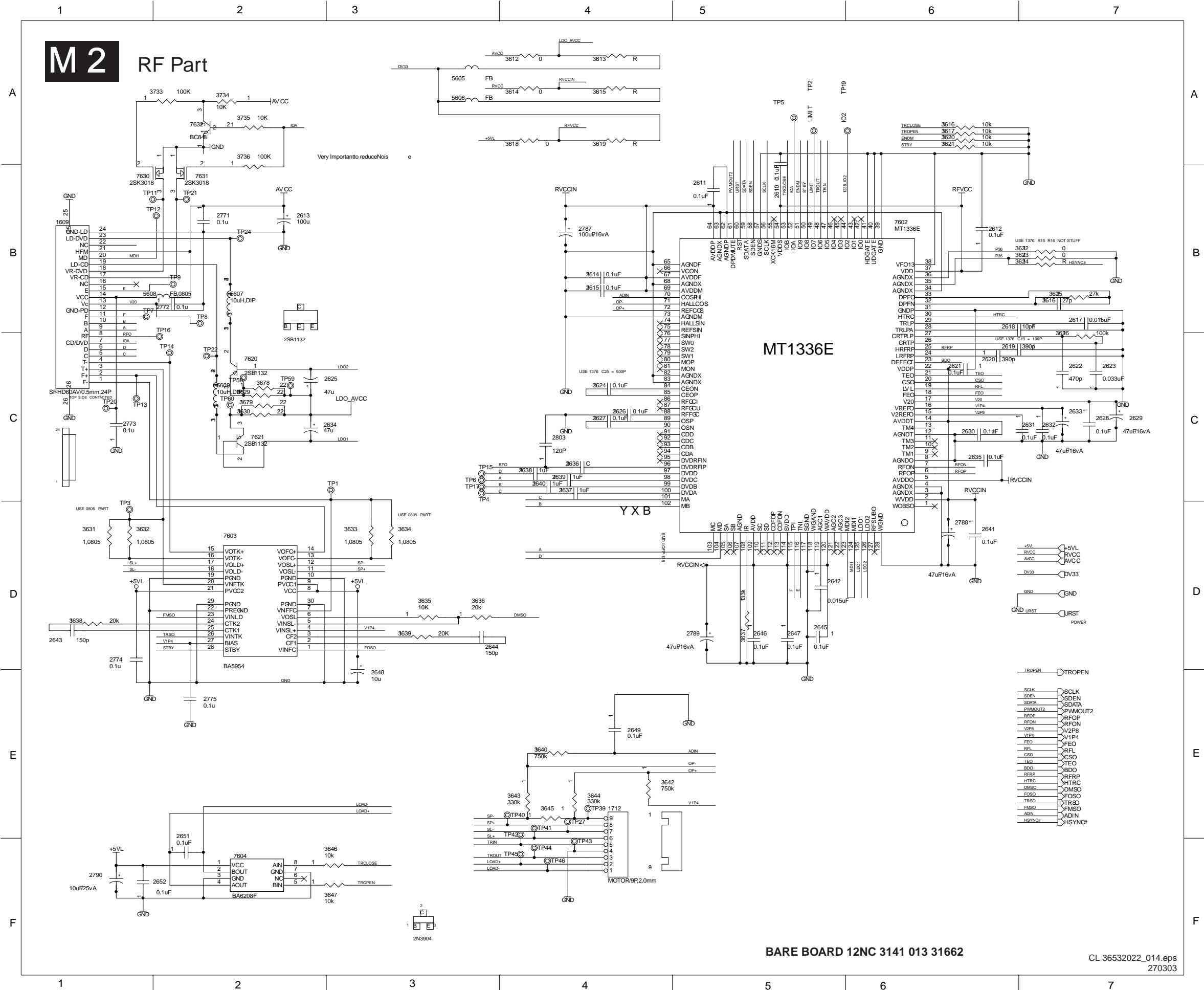

- 1609 C1
- 1712 F4
- 2610 B5
- 2611 B5
- 2612 B6
- 2613 B2
- 2614 B4
- 2615 B4
- 2616 B7
- 2617 B7
- 2618 B7
- 2619 C7
- 2620 C6
- 2621 C6
- 2622 C7
- 2623 C7
- 2624 C4
- 2625 C2
- 2626 C4
- 2627 C4
- 2628 C7
- 2629 C7
- 2630 C6
- 2631 C6
- 2632 C7
- 2633 C7
- 2634 C2
- 2635 C6
- 2636 C4
- 2637 C4
- 2638 C4
- 2639 C4
- 2640 C4
- 2641 D6
- 2642 D5
- 2643 D1
- 2644 D3
- 2645 D5
- 2646 D5
- 2647 D5
- 2648 D3
- 2649 E4
- 2651 F2
- 2652 F1
- 2653 C2
- 2654 F2
- 2655 F1
- 2656 C2
- 2657 B1
- 2658 C2
- 2659 C3
- 2660 A6
- 2661 A6
- 2662 B7
- 2663 B7
- 2664 B7
- 2665 B7
- 2666 C7
- 2667 C2
- 2668 D1
- 2669 D3
- 2670 D5
- 2671 D5
- 2672 D5
- 2673 D5
- 2674 F2
- 2675 F2
- 2676 A2
- 2677 A2
- 2678 A2
- 2679 A2
- 2680 A2
- 2681 B2
- 2682 B2
- 2683 B2
- 2684 B2
- 2685 B2
- 2686 B2
- 2687 B2
- 2688 D6
- 2689 D5
- 2690 F1
- 2691 C4
- 2692 A4
- 2693 A4
- 2694 A4
- 2695 A4
- 2696 A6
- 2697 A6
- 2698 A4
- 2699 A4
- 2700 A6
- 2701 A6
- 2702 A6
- 2703 A6
- 2704 D3
- 2705 D3
- 2706 D3
- 2707 D3
- 2708 D3
- 2709 D3
- 2710 D3
- 2711 D3
- 2712 D3
- 2713 D3
- 2714 D3
- 2715 D3
- 2716 D3
- 2717 D3
- 2718 D3
- 2719 D3
- 2720 D3
- 2721 D3
- 2722 D3
- 2723 D3
- 2724 D3
- 2725 D3
- 2726 D3
- 2727 D3
- 2728 D3
- 2729 D3
- 2730 D3
- 2731 D3
- 2732 D3
- 2733 A2
- 2734 A2
- 2735 A2
- 2736 B2
- 2737 B2
- 2738 B2
- 2739 B2
- 2740 B2
- 2741 B2
- 2742 B2
- 2743 B2
- 2744 B2
- 2745 B2
- 2746 B2
- 2747 B2
- 2748 B2
- 2749 B2
- 2750 B2
- 2751 B2
- 2752 B2
- 2753 B2
- 2754 B2
- 2755 B2
- 2756 B2
- 2757 B2
- 2758 B2
- 2759 B2
- 2760 B2
- 2761 B2
- 2762 B2
- 2763 B2
- 2764 B2
- 2765 B2
- 2766 B2
- 2767 B2
- 2768 B2
- 2769 B2
- 2770 B2
- 2771 B2
- 2772 B2
- 2773 C1
- 2774 D1
- 2775 E2
- 2776 B4
- 2777 B4
- 2778 D6
- 2779 D5
- 2780 F1
- 2781 C4
- 2782 A4
- 2783 A4
- 2784 A4
- 2785 A4
- 2786 A6
- 2787 A6
- 2788 A4
- 2789 A4
- 2790 A6
- 2791 A6
- 2792 A6
- 2793 A6
- 2794 A6
- 2795 A6
- 2796 A6
- 2797 A6
- 2798 A6
- 2799 A6
- 2800 C4
- 2801 A4
- 2802 A4
- 2803 C4
- 2804 A4
- 2805 A4
- 2806 A4
- 2807 A4
- 2808 A4
- 2809 A4
- 2810 A4
- 2811 A4
- 2812 A4
- 2813 A4
- 2814 A4
- 2815 A4
- 2816 A4
- 2817 A4
- 2818 A4
- 2819 A4
- 2820 A6
- 2821 A6
- 2822 B7
- 2823 B7
- 2824 B7
- 2825 B7
- 2826 C7
- 2827 C2
- 2828 D1
- 2829 D1
- 2830 D1
- 2831 D1
- 2832 D1
- 2833 D3
- 2834 D3
- 2835 D3
- 2836 D3
- 2837 D5
- 2838 D1
- 2839 D3
- 2840 E4
- 2841 E4
- 2842 E4
- 2843 E4
- 2844 E4
- 2845 E4
- 2846 F2
- 2847 F2
- 2848 A2
- 2849 A2
- 2850 A2
- 2851 B2
- 2852 B2
- 2853 B2
- 2854 B2
- 2855 B2
- 2856 B2
- 2857 B2
- 2858 B2
- 2859 B2
- 2860 B2
- 2861 B2
- 2862 B2
- 2863 B2
- 2864 B2
- 2865 B2
- 2866 B2
- 2867 B2
- 2868 B2
- 2869 B2
- 2870 B2
- 2871 B2
- 2872 B2
- 2873 B2
- 2874 B2
- 2875 B2
- 2876 B2
- 2877 B2
- 2878 B2
- 2879 B2
- 2880 B2
- 2881 B2
- 2882 B2
- 2883 B2
- 2884 B2
- 2885 B2
- 2886 B2
- 2887 B2
- 2888 B2
- 2889 B2
- 2890 B2
- 2891 B2
- 2892 B2
- 2893 B2
- 2894 B2
- 2895 B2
- 2896 B2
- 2897 B2
- 2898 B2
- 2899 B2
- 2900 B2

SD5.4 MPEG Board: Servo Part

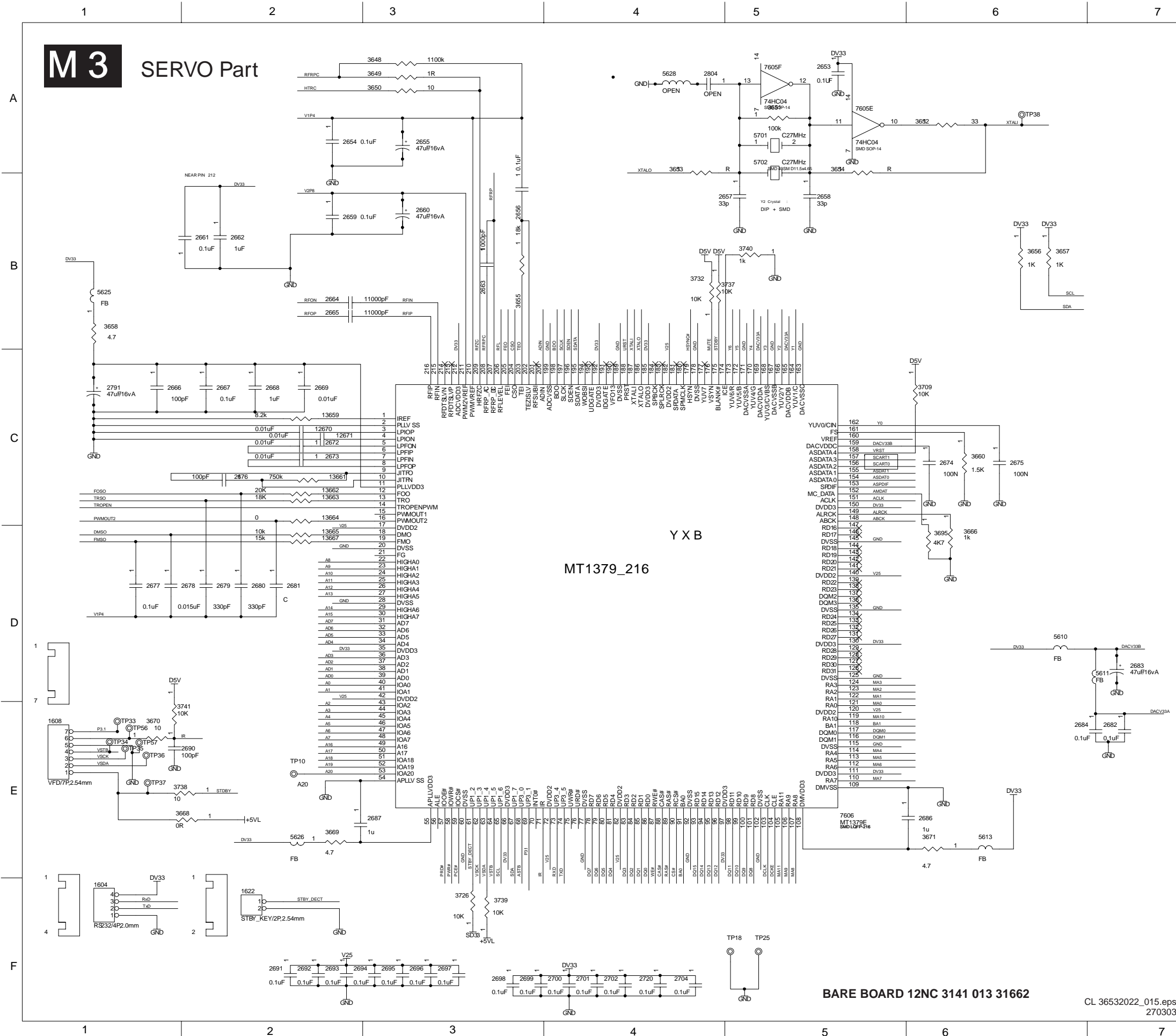

- 1604 F1 3670 E1
- 1608 E1 3671 E6
- 1622 F2 3695 D6
- 2653 A5 3709 C6
- 2654 A2 3726 F3
- 2655 A3 3732 B4
- 2656 B3 3737 B4
- 2657 B5 3738 E2
- 2658 B5 3739 F3
- 2659 B2 3740 B5
- 2660 B3 3741 E1
- 2661 B2 5610 D6
- 2662 B2 5611 D7
- 2663 B3 5613 E6
- 2664 B2 5625 B1
- 2665 B2 5626 E2
- 2666 C1 5628 A4
- 2667 C2 5701 A5
- 2668 C2 5702 A5
- 2669 C2 7605 A5
- 2670 C2 7605 A5
- 2671 C2 7606 C3
- 2672 C2 TP10 E2
- 2673 C2 TP18 F5
- 2674 C6 TP25 F5
- 2675 C6 TP33 E1
- 2676 C2 TP34 E1
- 2677 D1 TP35 E1
- 2678 D1 TP36 E1
- 2679 D2 TP37 E1
- 2680 D2 TP38 A6
- 2681 D2 TP56 E1
- 2682 E7 TP57 E1
- 2683 D7
- 2684 E7
- 2686 E6
- 2687 E2
- 2690 E1
- 2691 F2
- 2692 F2
- 2693 F2
- 2694 F3
- 2695 F3
- 2696 F3
- 2697 F3
- 2698 F3
- 2699 F3
- 2700 F4
- 2701 F4
- 2702 F4
- 2704 F4
- 2720 F4
- 2791 C1
- 2804 A4
- 3648 A3
- 3650 A3
- 3651 A5
- 3652 A6
- 3653 B4
- 3654 B5
- 3655 B3
- 3656 B6
- 3657 B1
- 3658 B1
- 3659 C2
- 3660 C6
- 3661 C2
- 3662 C2
- 3663 C2
- 3664 C2
- 3665 D2
- 3666 D6
- 3667 D2
- 3668 E2
- 3669 E2
- 3662 C2
- 3663 C2
- 3664 C2
- 3665 D2
- 3666 D6
- 3667 D2
- 3668 E2
- 3669 E2

SD5.4 MPEG Board: Memory & Audio Parts

**M 4** MEMORY & AUDIO PARTS

A  
B  
C  
D  
E  
F

2685 D2  
2703 E1  
2710 A2  
2711 A3  
2712 A3  
2713 A3  
2714 A3  
2715 A3  
2716 A3  
2717 B3  
2758 A5  
2760 A5  
2762 B7  
2763 B5  
2764 D5  
2765 C5  
2767 C5  
2769 C7  
2770 C5  
2776 D2  
2777 D2  
2793 A2  
2794 A2  
2795 D4  
2796 D5  
2797 D4  
2798 D4  
2799 E6  
2805 B6  
2806 C6  
2807 D6  
3608 C6  
3672 C3  
3673 D3  
3674 D3  
3675 D3  
3680 D1  
3710 A4  
3711 A5  
3712 A5  
3713 B6  
3715 B4  
3716 B5  
3717 B5  
3719 C4  
3720 C5  
3721 E4  
3722 C5  
3723 E4  
3724 E4  
3725 C6  
3727 C4  
3728 C5  
3729 C5  
3731 B6  
3742 B6  
3743 C6  
3746 D1  
3808 D2  
3809 D2  
5614 B2  
5623 D4  
5624 D4  
5627 B2  
7609 B1  
7610 E1  
7611 C1  
7613 B5  
7613 C5  
7614 D5  
7615 E5  
7628 B6  
7629 C6  
TP54 B1

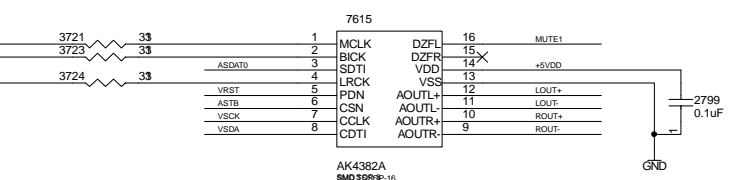
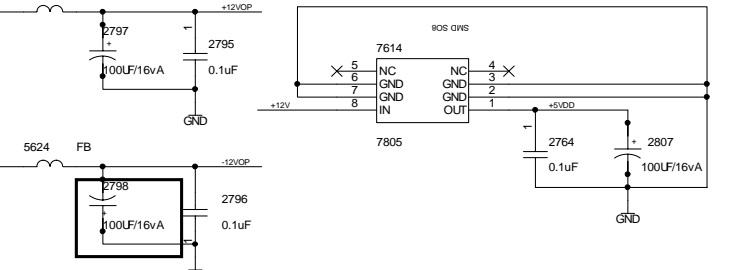
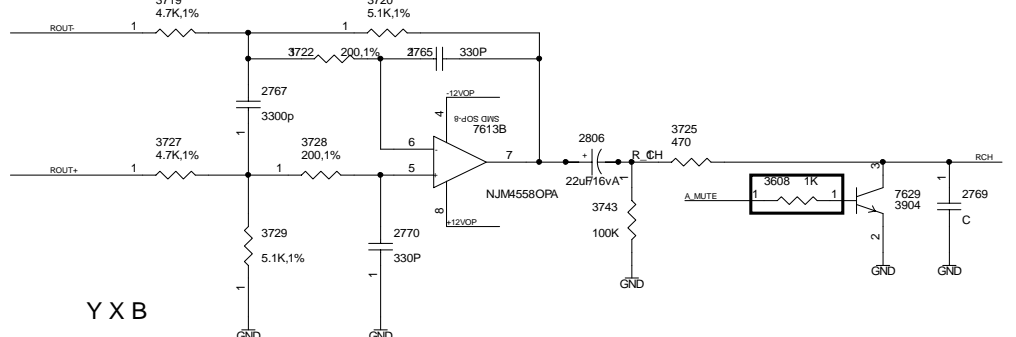
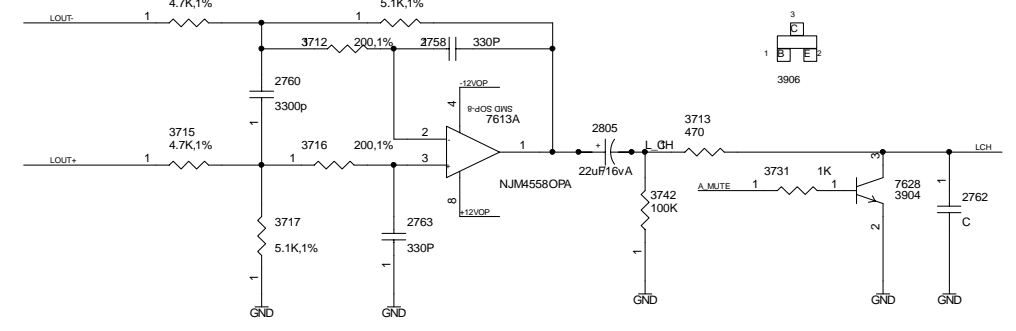
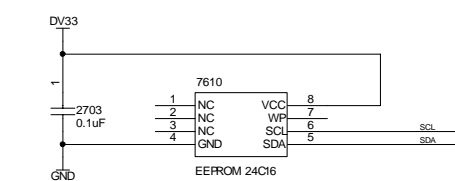
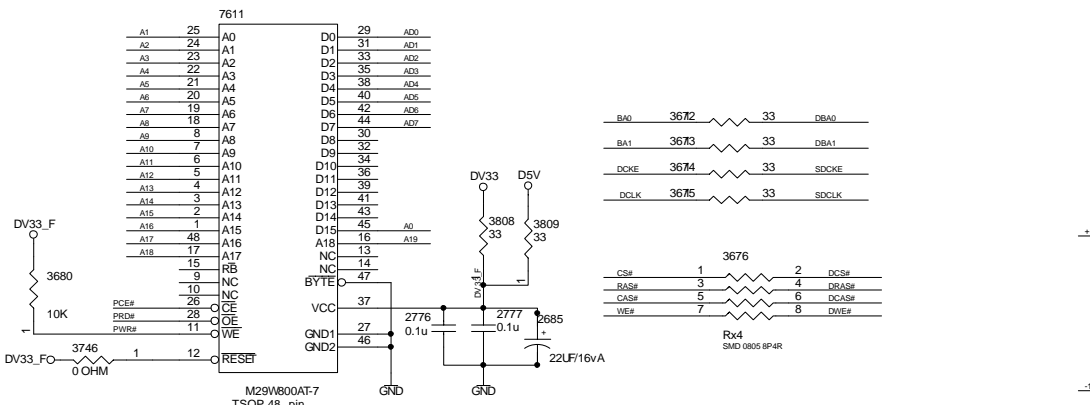
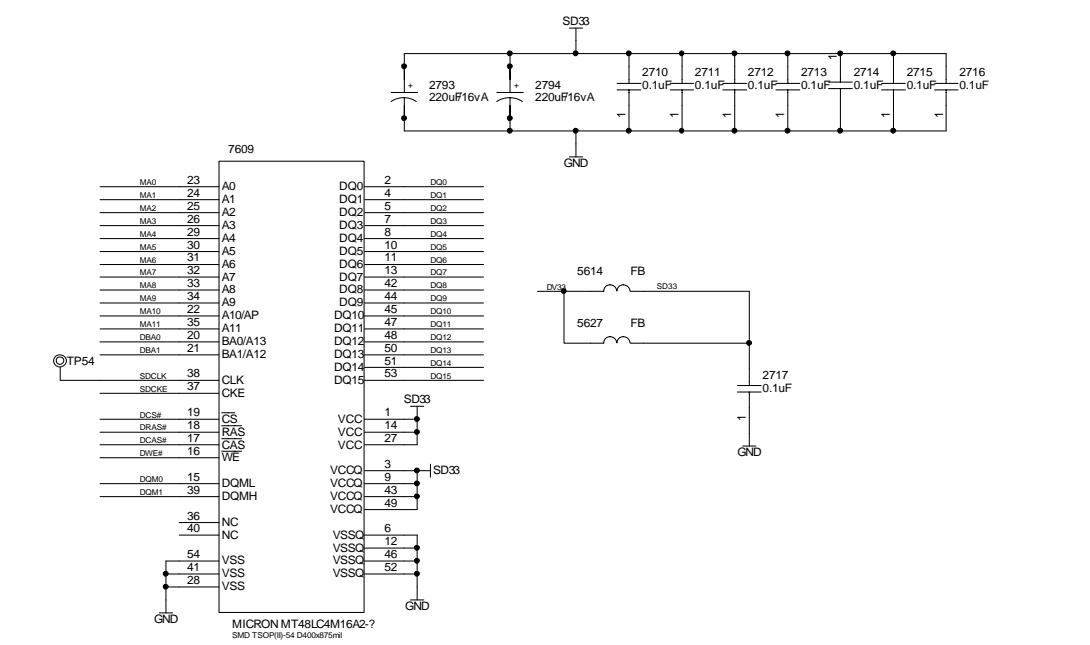

NAME	I/O	PULL H/L	PURPOSE
P30	O	H	ASTB
P31	I	H	1608 IR
P17	I/O	H	IIC SDA
P16	O	H	IIC SCK
P15	O	H	VSTB
P14	O	H	VSDA
P13	O	H	VSCK
P12	O	H	8 BANK USE
VSYNC	O	X	AUDIO MUTE
ASDAT3	O	L	1610
ASDAT4	O	L	VRST

SD5.4 MPEG Board: Video Part

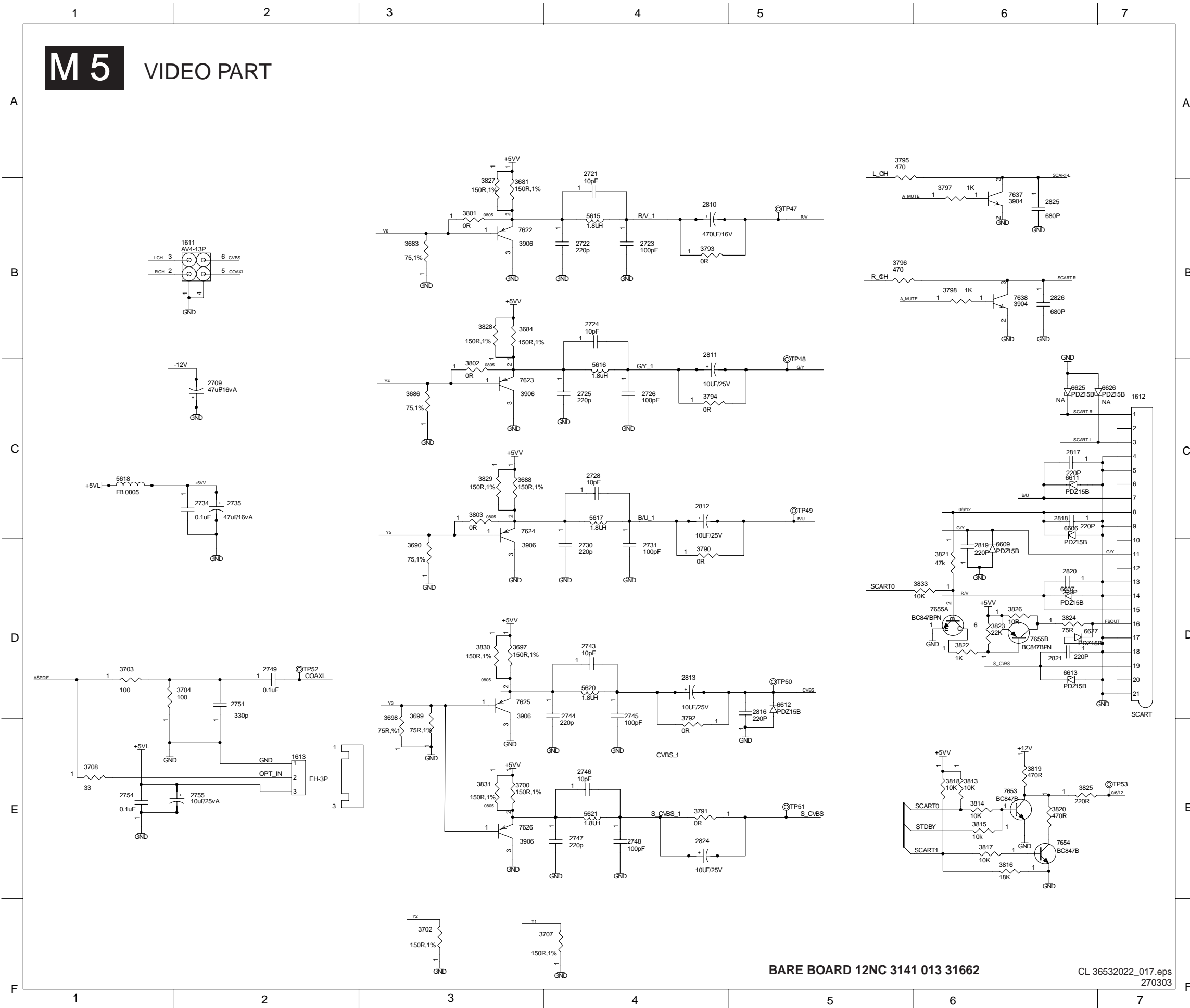

- 1611 B2 5616 C4
- 1612 C7 5617 C4
- 1613 E2 5618 C1
- 2709 C2 5620 D4
- 2721 B4 5621 E4
- 2722 B4 6606 C6
- 2723 B4 6607 D6
- 2724 B4 6609 D6
- 2725 C4 6611 C6
- 2726 C4 6612 E5
- 2728 C4 6613 D6
- 2730 D4 6625 C6
- 2731 D4 6626 C7
- 2734 C2 6627 D6
- 2735 C2 7622 B3
- 2743 D4 7623 C3
- 2744 D4 7624 C3
- 2745 D4 7625 D3
- 2746 E4 7626 E3
- 2747 E4 7637 B6
- 2748 E4 7638 B6
- 2749 D2 7653 E6
- 2751 D2 7654 E6
- 2754 E1 7655 D6
- 2755 E1 7655 D6
- 2810 B4 TP47 B5
- 2811 C4 TP48 B5
- 2812 C4 TP49 C5
- 2813 D4 TP50 D5
- 2816 D5 TP51 E5
- 2817 C6 TP52 D2
- 2818 C6 TP53 E7
- 2819 D6
- 2820 D6
- 2821 D6
- 2824 E4
- 2825 B6
- 2826 B6
- 3681 B3
- 3683 B3
- 3684 B3
- 3686 C3
- 3688 C3
- 3690 D3
- 3697 D3
- 3698 E3
- 3699 E3
- 3700 E3
- 3702 F3
- 3703 D1
- 3704 D2
- 3707 F4
- 3708 E1
- 3790 D4
- 3791 E4
- 3792 D4
- 3793 B4
- 3794 C4
- 3795 B5
- 3796 B5
- 3797 B6
- 3798 B6
- 3801 B3
- 3802 C3
- 3803 C3
- 3813 E6
- 3814 E6
- 3815 E6
- 3816 E6
- 3817 E6
- 3818 E6
- 3819 E6
- 3820 E6
- 3821 D6
- 3822 D6
- 3823 D6
- 3824 D6
- 3825 E6
- 3826 D6
- 3827 B3
- 3828 B3
- 3829 C3
- 3830 D3
- 3831 E3
- 3833 D6
- 5615 B4

Layout SD5.4 MPEG Board (Top Side)

1601 D2	2608 D4	2622 C5	2636 B4	2651 B2	2665 C4	2679 B2	2695 C3	2712 E2	2730 E6	2730 E6	2758 B6	2776 B3	2791 B3	2807 C6	3602 E3	3661 C4	3733 B5	5609 A4	7625 D
1604 C2	2609 B4	2623 C5	2637 B4	2652 C6	2666 B4	2680 B3	2696 D3	2713 D2	2731 E6	2731 E6	2760 B6	2777 B2	2793 D2	2810 D6	3603 E3	3662 B3	3734 B5	5610 D4	7626 D
1608 B2	2610 C5	2624 B5	2638 B4	2653 C5	2667 B4	2681 B2	2697 C4	2714 D3	2734 E5	2734 E5	2762 A6	2778 E3	2794 E2	2811 D6	3604 E4	3663 B2	3735 B5	5611 D4	7628 A
1609 A5	2611 B5	2625 B4	2639 B4	2654 C4	2668 B4	2682 D4	2698 D4	2715 C2	2735 E5	2735 E5	2763 B6	2779 E3	2795 B6	2812 E6	3605 E3	3664 B2	3736 B5	5613 D3	7629 B
1611 B6	2612 B5	2626 B5	2640 B4	2655 C4	2669 B4	2683 D4	2699 D4	2716 E2	2743 D6	2743 D6	2764 C6	2781 D2	2796 B6	2813 D6	3606 E3	3665 B3	3737 B2	5614 D2	7630 A
1612 D7	2613 B4	2627 B5	2641 C4	2656 C4	2670 C4	2684 D4	2700 D3	2717 D3	2744 D6	2744 D6	2765 B6	2782 C5	2797 B6	2816 D6	3607 E4	3666 D3	3738 B2	5615 D6	7631 A
1613 A6	2614 B5	2628 C5	2642 B4	2657 D4	2671 C4	2685 B2	2701 D3	2720 C3	2745 D6	2745 D6	2767 C6	2783 C2	2798 B6	2817 E6	3608 B6	3667 B2	3739 B2	5616 D6	7632 B
1622 C2	2615 B5	2629 C5	2643 B2	2658 D4	2672 C4	2686 D3	2702 D3	2721 D6	2746 D5	2746 D5	2769 B6	2784 C5	2799 C6	2818 C6	3609 E3	3668 B2	3740 D4	5617 E6	7633 E
1712 A2	2616 C5	2630 C4	2644 B3	2659 C4	2673 B4	2687 C3	2703 C2	2722 D6	2747 D5	2747 D5	2770 B6	2785 C2	2800 C2	2819 D6	3610 E4	3669 C3	3741 B2	5618 E5	7634 E
2601 E3	2617 C5	2631 C4	2645 B4	2660 C4	2674 D4	2690 B2	2704 C3	2723 D6	2748 D6	2748 D6	2771 B4	2786 B4	2802 B2	2820 D6	3611 C5	3670 B2	3742 B5	5620 D6	7635 D
2603 E2	2618 C5	2632 C4	2646 B4	2661 D5	2675 D4	2691 C2	2706 D3	2724 D6	2749 A6	2749 A6	2772 B5	2787 C4	2803 B5	2821 D6	3612 B4	3671 D3	3743 B6	5621 D6	7636 D
2605 C1	2619 C5	2633 B3	2647 B4	2662 C4	2676 B4	2692 C3	2709 E4	2725 D6	2751 A6	2751 A6	2773 B5	2788 B4	2804 D5	2824 D6	3613 B4	3672 D3	3744 E2	5623 B6	7637 B
2606 D4	2620 C5	2634 B4	2648 B2	2663 C4	2677 B2	2693 D3	2710 C2	2726 D6	2754 A5	2754 A5	2774 A3	2789 B5	2805 B5	2825 B6	3614 C5	3673 D3	3746 B2	5624 B6	7638 B
2607 C5	2621 C5	2635 C4	2649 B5	2664 C4	2678 B3	2694 C3	2711 D2	2728 E6	2755 A5	2755 A5	2775 B2	2790 B2	2806 B6	2826 C6	3615 C5	3674 D3	3747 D3	5625 B4	7653 C

3616 B2	3675 D3	3748 D3	5626 C3	7654 C
3617 B2	3676 C3	3749 D4	5627 D2	7655 C
3618 C5	3678 B4	3790 E6	5628 D5	TP2 B
3619 C5	3679 B4	3791 D6	5701 D4	TP10 C
3620 B5	3680 B2	3792 D6	5702 D4	TP19 B
3621 B5	3681 D5	3793 D6	6601 E4	TP58 B
3622 C5	3683 D5	3794 D6	6602 E3	TP59 B
3623 D5	3684 D6	3795 B6	6603 E3	TP60 B
3624 D5	3686 D5	3796 B6	6604 C2	
3625 C5	3688 E6	3797 B6	6605 C5	
3626 C5	3690 E5	3798 B6	6606 C6	
3627 E4	3695 D4	3801 D5	6607 D6	
3628 E2	3697 D6	3802 D5	6609 D6	
3629 B4	3698 E5	3803 E5	6611 E6	
3630 B4	3699 E5	3808 B2	6612 D6	
3631 A3	3700 D5	3809 B2	6613 D6	
3632 A3	3702 D4	3813 C5	6620 E4	
3633 A3	3703 A6	3814 C6	6621 E4	
3634 A3	3704 A6	3815 C6	6622 E3	
3635 B3	3707 D4	3816 C6	6623 E4	
3636 B3	3708 A6	3817 C6	6624 E2	
3637 B4	3709 D4	3818 C6	6625 C6	
3638 B2	3710 C6	3819 C6	6626 C6	
3639 B3	3711 B6	3820 C6	6627 C6	
3640 B5	3712 B6	3821 C6	7601 C2	
3642 B3	3713 A6	3822 C6	7602 B5	
3643 A3	3714 E3	3823 C6	7603 B3	
3644 B3	3715 C6	3824 C6	7604 B2	
3645 A3	3716 B6	3825 C6	7605 D5	
3646 B2	3717 B6	3826 C6	7606 C3	
3647 B2	3718 E2	3827 D6	7609 D2	
3648 C4	3719 C6	3828 D6	7610 C2	
3649 C4	3720 B6	3829 E5	7611 B3	
3650 C5	3721 C5	3830 D5	7613 B6	
3651 D4	3722 B6	3831 D5	7614 C6	
3652 D4	3723 C5	3832 D3	7615 C6	
3653 D4	3724 C5	3833 C6	7616 E3	
3654 D4	3725 B6	5602 C2	7617 E4	
3655 C4	3726 E2	5603 C5	7618 E3	
3656 C2	3727 B6	5604 B4	7620 B4	
3657 C2	3728 B6	5605 B4	7621 A4	
3658 B4	3729 B6	5606 C5	7622 D5	
3659 C4	3731 A6	5607 A4	7623 D5	
3660 D4	3732 E3	5608 B4	7624 E5	

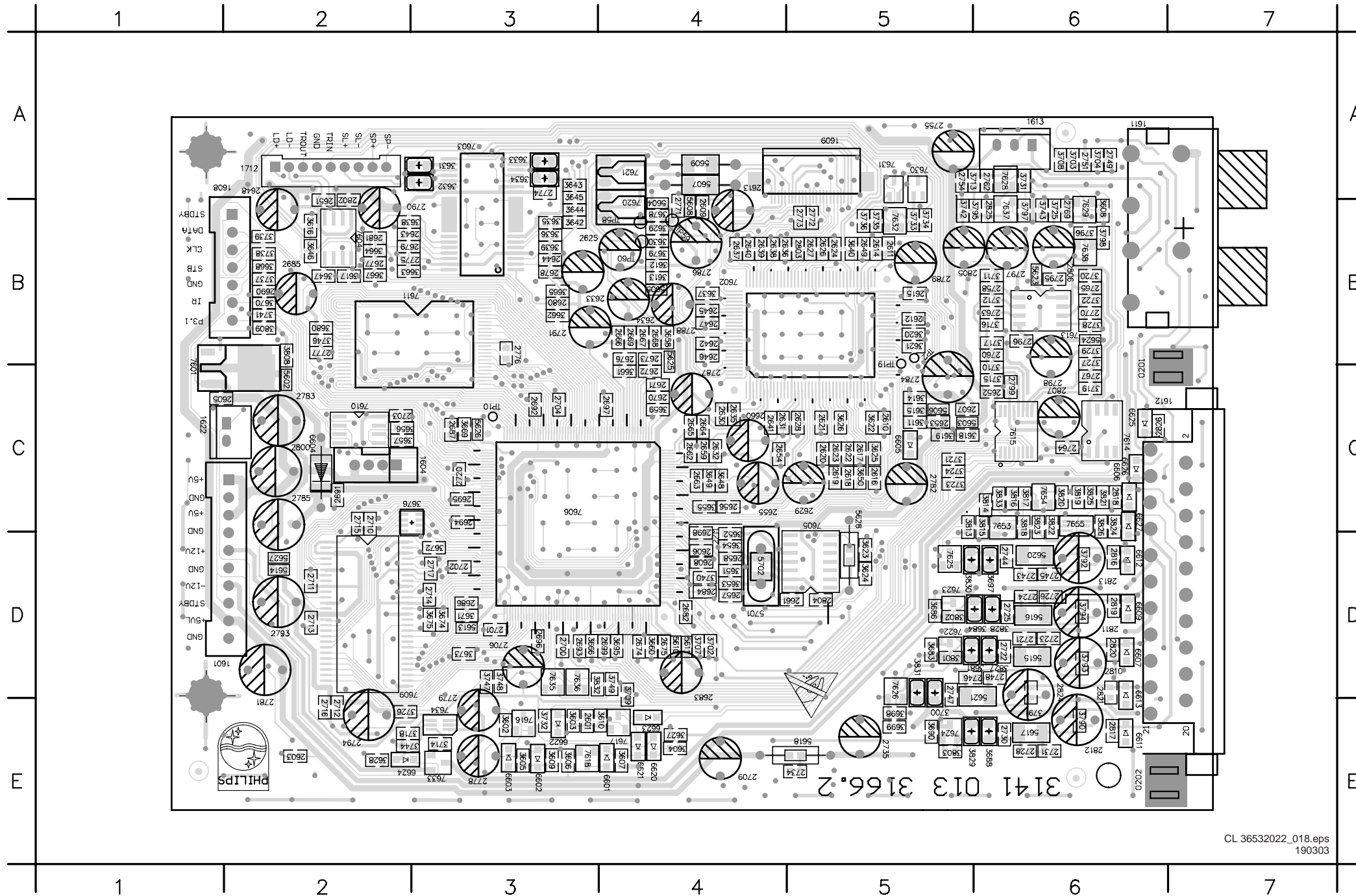

CL 36532022\_018.eps  
190303





## 8. Alignments

Not applicable.

## 9. Circuit Descriptions, List of Abbreviations, and IC Data

### 9.1 Circuit Descriptions

Not applicable.

### 9.2 List of abbreviations

Not applicable.

9.3 IC Data

In this paragraph, the internal block diagrams and pinning are given of ICs that are drawn as 'black box' in the electrical diagrams (with exception of 'memory' and 'logic' ICs).

9.3.1 Diagram Power Supply: TY72011P2 (item 7130)

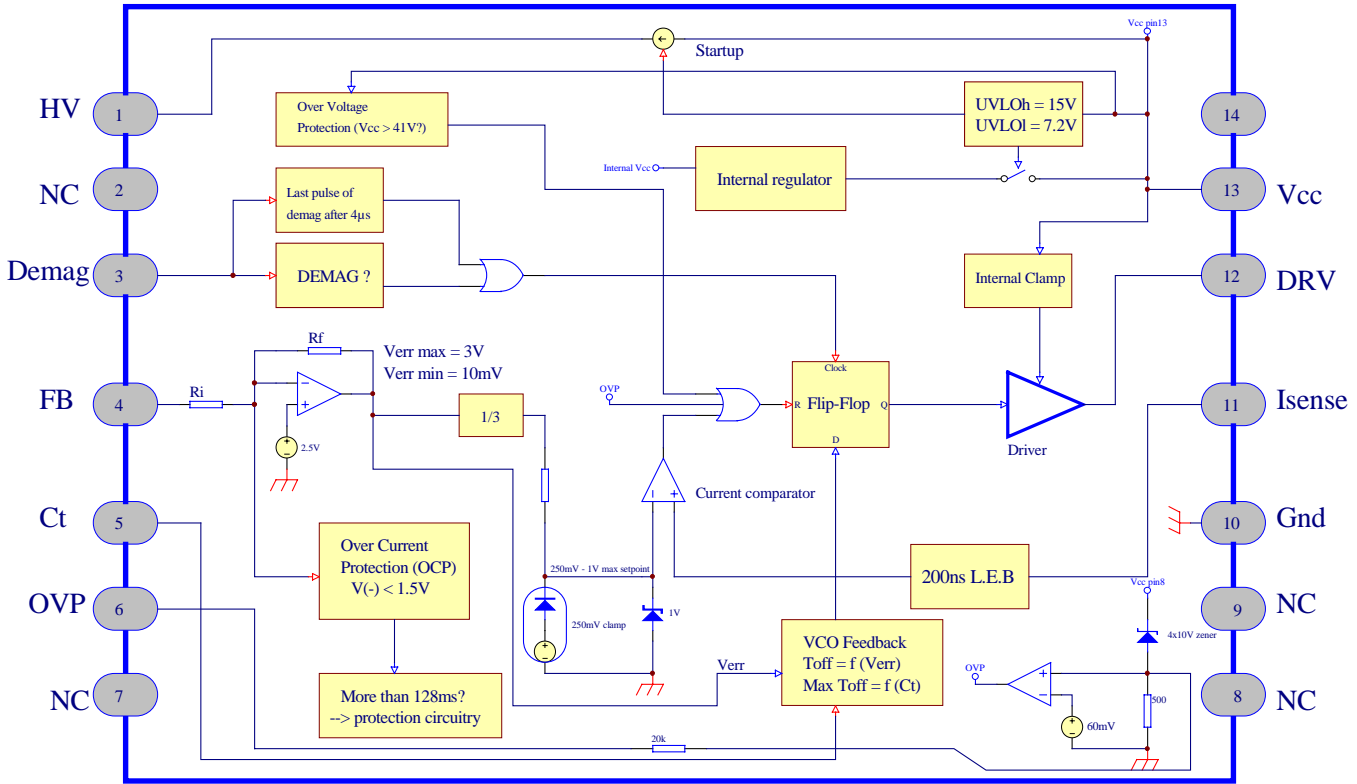

Figure 9-1 Block diagram TY72011P2

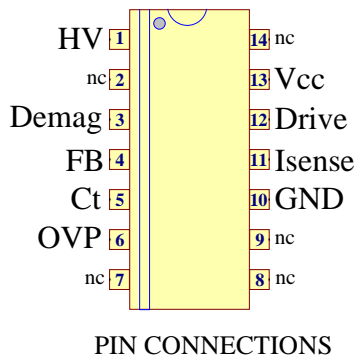

Figure 9-2 Pinning TY72011P2

## 10. Spare Parts List

<b>Mechanical DVD728 /001</b>			<b>Mechanical DVD729 /021</b>			2603 2238 586 59812 0603 50V 100NP80M		
<b>Various</b>			<b>Various</b>			2605 2238 586 59812 0603 50V 100NP80M		
1	3139 247 59541	FRONT ASSY DVD728/001	1	3139 247 59061	FRONT ASSY DVD729/001	2606 2238 586 59812 0603 50V 100NP80M		
15	3139 429 00131	POWER SUPPLY UNIT	15	3139 429 00131	POWER SUPPLY UNIT	2607 2238 586 59812 0603 50V 100NP80M		
50	3141 018 03810	DVD LOADER A97SL(NO SERVO)	50	3141 018 03810	DVD LOADER A97SL(NO SERVO)	2608 2238 586 59812 0603 50V 100NP80M		
200	3141 017 78431	BACK PLATE DVD727/001 PPT	200	3141 017 78431	BACK PLATE DVD727/001 PPT	2609 2238 586 59812 0603 50V 100NP80M		
250	3139 247 58501	COVERTOP DVD760 PPT	250	3139 247 59051	COVER TOP DVD729 PPT	2610 2238 586 59812 0603 50V 100NP80M		
300	3141 017 90220	REMOTE CONTROL DVD-Q30/751	300	3141 017 90200	REMOTE CONTROL RC2K14	2611 2238 586 59812 0603 50V 100NP80M		
310	3141 018 71300	MAIN CORD M7.92VH 1.60M	310	3141 018 71300	MAIN CORD M7.92VH 1.60M	2612 2238 586 59812 0603 50V 100NP80M		
322	2422 076 00445	CORD SCART 1M1 M 20P BK	322	2422 076 00445	CORD SCART 1M1 M 20P BK	2613 4822 124 40207 100µF 20% 25V		
325	3103 308 92610	CABLE AUDIO 2X2RCA MALE 1.5MTR	325	3103 308 92610	CABLE AUDIO 2X2RCA MALE 1.5MTR	2614 2238 586 59812 0603 50V 100NP80M		
330	3139 246 12381	IFU DVD728/001	330	3139 246 12921	IFU DVD728/021	2615 2238 586 59812 0603 50V 100NP80M		
<b>Mechanical DVD728 /021</b>			<b>Mechanical DVD729 /051</b>			2616 4822 126 11669 27pF		
<b>Various</b>			<b>Various</b>			2617 3198 017 31530 0603 50V 15nF COL R		
1	3139 247 59541	FRONT ASSY DVD728/001	1	3139 247 59061	FRONT ASSY DVD729/001	2618 4822 122 33741 10pF 10% 50V		
15	3139 429 00131	POWER SUPPLY UNIT	15	3139 429 00131	POWER SUPPLY UNIT	2619 4822 126 14315 190pF 5% 50V 0603		
50	3141 018 03810	DVD LOADER A97SL(NO SERVO)	50	3141 018 03810	DVD LOADER A97SL(NO SERVO)	2620 4822 126 14315 390pF 5% 50V 0603		
200	3141 017 78431	BACK PLATE DVD727/001 PPT	200	3141 017 78431	BACK PLATE DVD727/001 PPT	2621 2238 586 59812 0603 50V 100NP80M		
250	3139 247 58501	COVERTOP DVD760 PPT	250	3139 247 59051	COVER TOP DVD729 PPT	2622 4822 126 13881 470pF 5% 50V		
300	3141 017 90220	REMOTE CONTROL DVD-Q30/751	300	3141 017 90200	REMOTE CONTROL RC2K14	2623 4822 126 14549 33nF 16V 0603		
310	3141 018 71300	MAIN CORD M7.92VH 1.60M	310	4822 321 11207	MAINS CORD & FUSE 14" GB /05	2624 2238 586 59812 0603 50V 100NP80M		
322	2422 076 00445	CORD SCART 1M1 M 20P BK	322	2422 076 00445	CORD SCART 1M1 M 20P BK	2625 4822 124 81286 47µF 20% 16V		
325	3103 308 92610	CABLE AUDIO 2X2RCA MALE 1.5MTR	325	3103 308 92610	CABLE AUDIO 2X2RCA MALE 1.5MTR	2626 2238 586 59812 0603 50V 100NP80M		
330	3139 246 12921	IFU DVD728/021	330	3139 246 12911	IFU DVD728/051	2627 2238 586 59812 0603 50V 100NP80M		
<b>Mechanical DVD728 /051</b>			<b>Mechanical DVD731 /001</b>			2628 2238 586 59812 0603 50V 100NP80M		
<b>Various</b>			<b>Various</b>			2629 4822 124 81286 47µF 20% 16V		
1	3139 247 59541	FRONT ASSY DVD728/001	1	3139 247 59081	FRONT ASSY DVD731/001	2630 2238 586 59812 0603 50V 100NP80M		
15	3139 429 00131	POWER SUPPLY UNIT	15	3139 429 00131	POWER SUPPLY UNIT	2631 2238 586 59812 0603 50V 100NP80M		
50	3141 018 03810	DVD LOADER A97SL(NO SERVO)	50	3141 018 03810	DVD LOADER A97SL(NO SERVO)	2632 2238 586 59812 0603 50V 100NP80M		
200	3141 017 78431	BACK PLATE DVD727/001 PPT	200	3141 017 78431	BACK PLATE DVD727/001 PPT	2633 4822 124 81286 47µF 20% 16V		
250	3139 247 58501	COVERTOP DVD760 PPT	250	3139 247 58501	COVERTOP DVD760 PPT	2634 4822 124 81286 47µF 20% 16V		
300	3141 017 90220	REMOTE CONTROL DVD-Q30/751	300	3141 017 90220	REMOTE CONTROL DVD-Q30/751	2635 2238 586 59812 0603 50V 100NP80M		
310	4822 321 11207	MAINS CORD & FUSE 14" GB /05	310	3141 018 71300	MAIN CORD M7.92VH 1.60M	2636 3198 017 41050 0603 10V 1µF COL R		
322	2422 076 00445	CORD SCART 1M1 M 20P BK	322	2422 076 00445	CORD SCART 1M1 M 20P BK	2637 3198 017 41050 0603 10V 1µF COL R		
325	3103 308 92610	CABLE AUDIO 2X2RCA MALE 1.5MTR	325	3103 308 92610	CABLE AUDIO 2X2RCA MALE 1.5MTR	2638 3198 017 41050 0603 10V 1µF COL R		
330	3139 246 12911	IFU DVD728/051	330	3139 246 12381	IFU DVD728/001	2639 3198 017 41050 0603 10V 1µF COL R		
<b>Mechanical DVD729 /001</b>			<b>Mono PWB SD5.42</b>			2640 3198 017 41050 0603 10V 1µF COL R		
<b>Various</b>			<b>Various</b>			2641 2238 586 59812 0603 50V 100NP80M		
1	3139 247 59061	FRONT ASSY DVD729/001	1601	4822 267 10557	B10B-EH-A	2642 3198 016 31020 0603 25V 1nF		
15	3139 429 00131	POWER SUPPLY UNIT	1604	2422 025 09406	CON BM 4P VERT PH-B	2643 3198 016 31020 0603 25V 1nF		
50	3141 018 03810	DVD LOADER A97SL(NO SERVO)	1608	2422 025 17466	CON BM V 7P M 2.50 MIS B	2644 2020 552 94427 0603 50V 100P 5%		
200	3141 017 78431	BACK PLATE DVD727/001 PPT	1609	3141 010 30510	CON SM 0.5MM 24PIN	2645 2238 586 59812 0603 50V 100NP80M		
250	3139 247 59051	COVER TOP DVD729 PPT	1611	2422 026 05353	SOC CINCH H 4P F WHYERDBK Y	2646 3198 016 31020 0603 25V 1nF		
300	3141 017 90200	REMOTE CONTROL RC2K14	1612	2422 025 12352	CON BM EURO H 21P F BK GRND-L	2647 2020 552 94427 0603 50V 100P 5%		
310	3141 018 71300	MAIN CORD M7.92VH 1.60M	1613	4822 267 10735	B3B-EH-A	2648 2238 586 59812 0603 50V 100NP80M		
322	2422 076 00445	CORD SCART 1M1 M 20P BK	1622	2412 020 00724	CON BM V 2P M 2.50 EH B	2649 2238 586 59812 0603 50V 100NP80M		
325	3103 308 92610	CABLE AUDIO 2X2RCA MALE 1.5MTR	1712	2422 025 10769	CON BMT 9P VERT PH-B	2650 2238 586 59812 0603 50V 100NP80M		
330	3139 246 12381	IFU DVD728/001	— —			2651 2238 586 59812 0603 50V 100NP80M		
						2652 2238 586 59812 0603 50V 100NP80M		
						2653 2238 586 59812 0603 50V 100NP80M		
						2654 2238 586 59812 0603 50V 100NP80M		
						2655 4822 124 81286 47µF 20% 16V		
						2656 2238 586 59812 0603 50V 100NP80M		
						2657 2222 867 15339 0603 50V 33P 5%		
						2658 2222 867 15339 0603 50V 33P 5%		
						2659 2238 586 59812 0603 50V 100NP80M		
						2660 4822 124 81286 47µF 20% 16V		
						2661 2238 586 59812 0603 50V 100NP80M		
						2662 3198 017 41050 0603 10V 1µF COL R		
						2663 3198 016 31020 0603 25V 1nF		
						2664 3198 016 31020 0603 25V 1nF		
						2665 3198 016 31020 0603 25V 1nF		
						2666 2020 552 94427 0603 50V 100P 5%		
						2667 2238 586 59812 0603 50V 100NP80M		
						2668 3198 017 41050 0603 10V 1µF COL R		
						2669 5322 126 11583 10nF 10% 50V 0603		
						2670 5322 126 11583 10nF 10% 50V 0603		
						2671 5322 126 11583 10nF 10% 50V 0603		
						2672 5322 126 11583 10nF 10% 50V 0603		
						2673 5322 126 11583 10nF 10% 50V 0603		
						2674 2238 586 59812 0603 50V 100NP80M		
						2675 2020 552 94427 0603 50V 100P 5%		
						2676 2238 586 59812 0603 50V 100NP80M		
						2677 3198 017 31530 0603 50V 15nF COL R		
						2678 4822 126 14241 0603 50V 330P COL R		
						2679 4822 126 14241 0603 50V 330P COL R		
						2680 4822 126 14241 0603 50V 330P COL R		
						2681 2238 586 59812 0603 50V 100NP80M		
						2682 4822 124 81286 47µF 20% 16V		
						2683 2238 586 59812 0603 50V 100NP80M		
						2684 4822 124 81151 22µF 50V		
						2685 3198 017 41050 0603 10V 1µF COL R		
						2686 3198 017 41050 0603 10V 1µF COL R		
						2687 2020 552 94427 0603 50V 100P 5%		
						2688 2238 586 59812 0603 50V 100NP80M		
						2689 2238 586 59812 0603 50V 100NP80M		
						2690 2238 586 59812 0603 50V 100NP80M		
						2691 2238 586 59812 0603 50V 100NP80M		
						2692 2238 586 59812 0603 50V 100NP80M		
						2693 2238 586 59812 0603 50V 100NP80M		
						2694 2238 586 59812 0603 50V 100NP80M		
						2695 2238 586 59812 0603 50V 100NP80M		
						2696 2238 586 59812 0603 50V 100NP80M		
						2697 2238 586 59812 0603 50V 100NP80M		
						2698 2238 586 59812 0603 50V 100NP80M		



6603	4822 130 11397	BAS316
6604	3141 018 80811	DIO REC SM GS1B (PNJT)
6605	4822 130 11397	BAS316
6606	4822 130 11522	UDZ15B
6607	4822 130 11522	UDZ15B
6609	4822 130 11522	UDZ15B
6611	4822 130 11522	UDZ15B
6612	4822 130 11522	UDZ15B
6613	4822 130 11522	UDZ15B
6620	4822 130 11397	BAS316
6621	4822 130 11397	BAS316
6622	4822 130 11397	BAS316
6623	4822 130 11397	BAS316
6627	4822 130 11522	UDZ15B



7601	4822 209 17398	LD1117DT33
7602	3141 018 51650	IC SM MT1336E
7603	9322 187 63668	IC SM BA5954FP(RHMO) R
7604	3141 018 51660	IC SM BA6208F
7605	5322 209 11517	PC74HCU04T
7606	3141 018 51640	IC SM MT1379E
7609	3141 018 51280	IC SM 48LC4M16A2 (MICRON)
7610	4822 209 17226	M24C08-WMN6
7613	4822 209 83357	NJM4560M JRC
7614	4822 209 33411	MC78L05ACD
7615	9322 177 09685	IC SM AK4382AVT (AKMO) R
7616	4822 130 60373	BC856B
7617	4822 130 60373	BC856B
7618	4822 130 60373	BC856B
7620	4822 130 11565	2SB1132
7621	4822 130 11565	2SB1132
7625	3141 018 51700	TRA SM 3906 SOT23
7626	3141 018 51700	TRA SM 3906 SOT23
7628	5322 130 60159	BC846B
7629	5322 130 60159	BC846B
7630	3141 018 51690	TRA SM 2SK3018
7631	3141 018 51690	TRA SM 2SK3018
7632	5322 130 60159	BC846B
7633	4822 130 60373	BC856B
7634	9340 425 30115	TRA SIG SM BC847BPN (PHSE) R
7637	5322 130 60159	BC846B
7638	5322 130 60159	BC846B
7653	5322 130 60159	BC846B
7654	5322 130 60159	BC846B

## Front PWB

### Various

41	3141 014 25380	FTD HOLDER DVD625K
1400	3141 010 50311	VFD HNV-07SS54T (SAMSUNG)
1405	2422 025 16343	CON BM V 2P M 2.50 EH BK B
1410	4822 276 13114	SWITCH
1411	4822 276 13114	SWITCH
1412	4822 276 13114	SWITCH
1413	4822 276 13114	SWITCH
1415	4822 276 13114	SWITCH

—||—

2401	4822 126 14238	0603 50V 2N2 COL R
2402	2238 586 59812	0603 50V 100NP80M
2403	4822 124 40769	4.7μF 20% 100V
2409	4822 126 14549	33nF 16V O6O3
2411	4822 124 42084	100μF 20% 35V
2414	2238 586 59812	0603 50V 100NP80M
2415	4822 124 22651	1.0μF 20% 50V
2416	4822 124 42084	100μF 20% 35V

—WW—

3400	4822 051 30471	470Ω 5% 0.062W
3401	4822 051 30333	33k 5% 0.062W
3402	4822 051 30103	10k 5% 0.062W
3403	4822 051 30103	10k 5% 0.062W
3404	4822 051 30103	10k 5% 0.062W
3405	4822 051 30102	1k 5% 0.062W
3406	4822 051 30103	10k 5% 0.062W
3407	4822 051 30479	47Ω 5% 0.062W
3408	4822 051 30472	4k7 5% 0.062W
3409	4822 051 30472	4k7 5% 0.062W
3410	4822 051 30472	4k7 5% 0.062W
3411	4822 051 30472	4k7 5% 0.062W

3415	4822 051 30101	100Ω 5% 0.062W
3416	4822 051 30101	100Ω 5% 0.062W
3417	4822 051 30101	100Ω 5% 0.062W
3418	4822 051 30109	10Ω 5% 0.062W
3420	4822 051 30331	330Ω 5% 0.062W
3421	4822 051 30471	470Ω 5% 0.062W
3422	4822 051 30103	10k 5% 0.062W
3423	4822 051 30331	330Ω 5% 0.062W
3424	4822 051 30331	330Ω 5% 0.062W
3425	4822 051 30472	4k7 5% 0.062W
3426	4822 051 30472	4k7 5% 0.062W
3427	4822 051 30103	10k 5% 0.062W
3428	4822 051 30471	470Ω 5% 0.062W
3441	4822 051 30008	0Ω jumper
3442	4822 051 20008	0Ω jumper . (0805)
3443	4822 051 20008	0Ω jumper . (0805)
3444	4822 051 20008	0Ω jumper . (0805)
3445	4822 051 20008	0Ω jumper . (0805)
3446	4822 051 30008	0Ω jumper
3447	4822 051 20008	0Ω jumper . (0805)
3448	4822 051 30008	0Ω jumper
3449	4822 051 20008	0Ω jumper . (0805)
3450	4822 051 30008	0Ω jumper
3451	4822 051 30008	0Ω jumper
3452	4822 051 20008	0Ω jumper . (0805)
3453	4822 051 30008	0Ω jumper
3454	4822 051 30008	0Ω jumper
3455	4822 051 30008	0Ω jumper
3457	4822 051 30008	0Ω jumper
3458	4822 051 30008	0Ω jumper
3460	4822 051 30008	0Ω jumper
3461	4822 051 20008	0Ω jumper . (0805)
3462	4822 051 30008	0Ω jumper
3463	4822 051 20008	0Ω jumper . (0805)
3464	4822 051 30008	0Ω jumper
3465	4822 051 20008	0Ω jumper . (0805)
3466	4822 051 30008	0Ω jumper
3467	4822 051 20008	0Ω jumper . (0805)

→|←

6400	4822 130 11397	BAS316
6401	4822 130 34167	BZX79-B6V2
6402	3141 018 80801	LED RED DIF LTL-4221N-011
6403	4822 130 11397	BAS316



7400	9322 186 03671	IC SM UPD16312GB-3B4 (NECO) Y
7401	5322 130 60159	BC846B
7402	4822 130 60373	BC856B
7403	5322 130 60159	BC846B
7404	3141 010 50260	IR RECEIVER HK361BT-16

## AV PWB

—||—

2501	2238 586 59812	0603 50V 100NP80M
2502	4822 124 11946	22μF 20% 16V

—WW—

3501	4822 051 30339	33Ω 5% 0.062W
------	----------------	---------------



7501	9322 155 28667	OPT FIB CON GP1FA550TZ (SRPJ)L
------	----------------	--------------------------------

# 11. Revision List

## 11.1 Revision List

First release